

HORIZONTAL SPLIT CASE PUMP



VERTICAL SPLIT CASE PUMP

FAIRBANKS NIJHUIS™ 900 SERIES SPLIT CASE FIRE PUMPS

Built Per NFPA 20



FAIRBANKS NIJHUIS™ 900 SERIES

Split Case Fire Pumps

Horizontal split case pumps are the most common type of fire pump. These pumps are specifically designed and tested for fire service applications where reliability of performance is of vital importance. Split case pumps are characterized by:

- Easy access to all working parts;
- Rugged construction;
- Liberal water passages; and
- Efficient operation.

Split case fire pumps are specified when the source of water is located above the surface of the ground and provides a positive suction pressure to the pump at any performance point. Single-stage or multistage pumps are available dependent upon discharge pressure requirements.

Fairbanks Nijhuis split case fire pumps are built per the rigid standards of NFPA 20 and are listed by Underwriters Laboratories (UL) and approved by Factory Mutual (FM).

Available in a broad range of operating pressures and flows from a minimum of 250 GPM, Fairbanks Nijhuis split case pumps can be driven by either an electric motor or diesel engine. Fairbanks Nijhuis' UL-Listed, FM-Approved fire pump packages also include the system controller, with a full range of options and accessories available to complete the NFPA-compliant fire pump package.

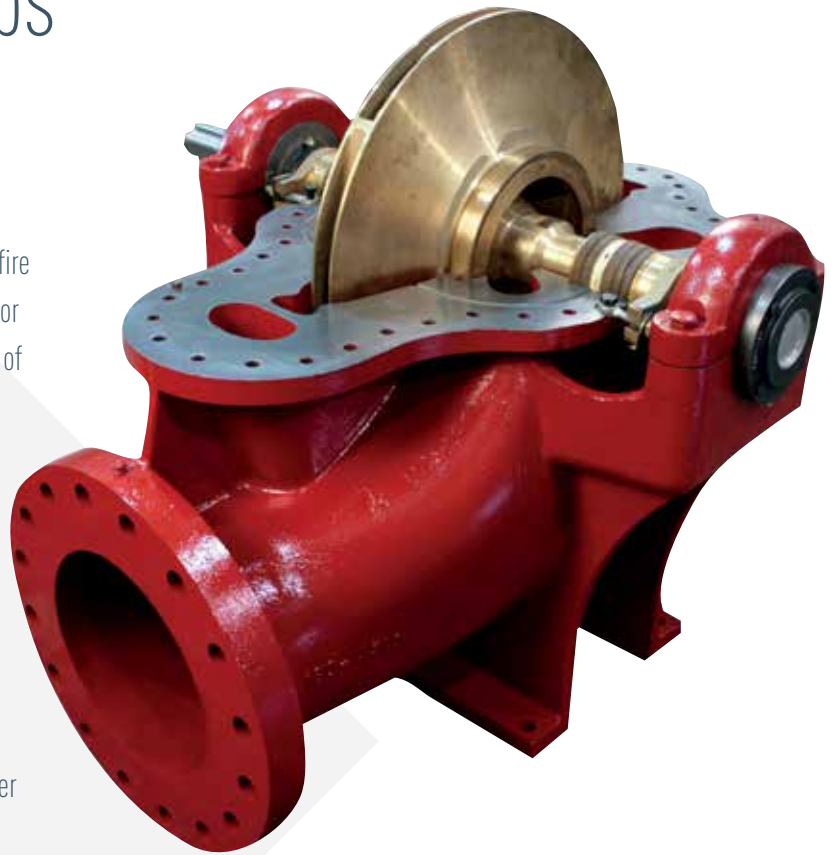

In addition to horizontal split case pumps, Fairbanks Nijhuis also offers split case performance in a vertical format. Vertical fire pumps provide distinct advantages over horizontal pump constructions.

- Less floor space is required.
- In-line piping arrangement allows piping in any direction in most cases.
- Elevated motor protects against potential flooding if the pump station is in a low area.
- Components are register-fitted to prevent misalignment.

Pump Features

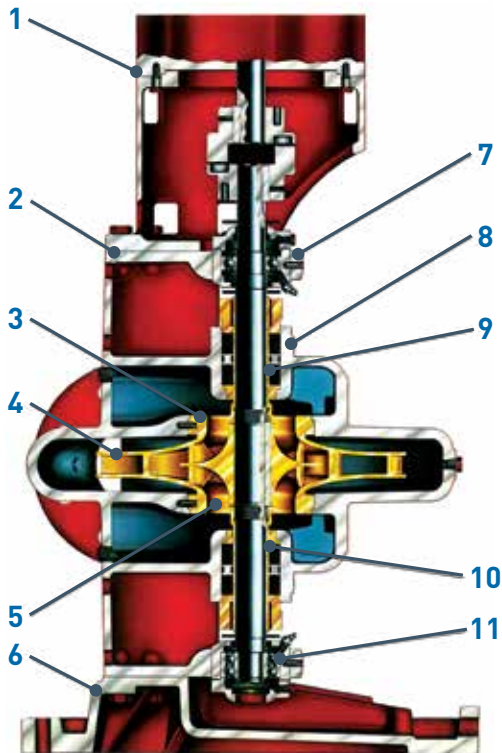

**VERTICAL
SPLIT CASE**

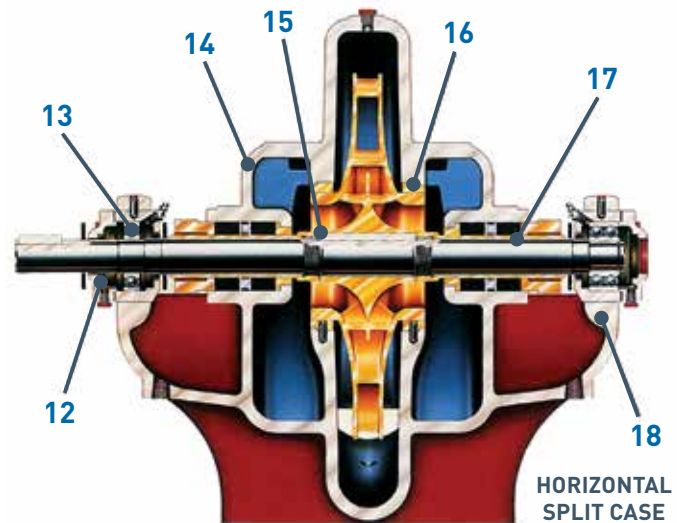

**HORIZONTAL
SPLIT CASE**

- 1. Computer Machined**
major components with 360 degree registered fits to assure concentricity of parts.
- 2. Integral Bearing Arms**
eliminate bearing misalignment and simplify maintenance.
- 3. Enclosed Impeller Design**
provides high efficiency and performance.
- 4. Dynamically Balanced Impeller**
is keyed to the shaft and secured by adjustable shaft sleeves.
- 5. Double Suction Impeller**
balances hydraulic thrust loads.
- 6. Cast Iron Drip Rim Base**
directs condensation and any stuffing box leakage to drain.
- 7. Short Bearing Span**
holds shaft deflection to .002" at face of stuffing box at maximum load.
- 8. Internal Water Seal Passages**
between volute and stuffing box cannot be damaged.
- 9. Interwoven, Graphite Impregnated T.F.E.**
diagonally cut packing rings seal the pump shaft.
- 10. Stuffing Boxes**
are extra deep for proper sealing. Split packing glands simplify packing maintenance.
- 11. Double Row Thrust**
ball bearing.
- 12. Grease Seals**
and nonsparking neoprene rotating slingers protect both bearings during pump operation and washdown.
- 13. Bearings**
selected for 50,000 hour minimum life at maximum load. Average bearing life 5 x minimum.
- 14. Split Case Design**
simplifies disassembly. The suction and discharge piping and shaft alignment are not disturbed.
- 15. O-Ring Sealed Shaft Sleeves**
prevent corrosion of the shaft. This eliminates the need for stainless steel shafts.
- 16. Case Wearing Rings**
and throttle bushings protect the casing from wear and are easily and inexpensively replaced.
- 17. Bronze Shaft Sleeve**
prevents shaft wear, is slip fit over the shaft, keylocked, and extends the entire length of the seal box.
- 18. Certified Performance Test with Positive Suction Pressure**
is provided for each fire pump for customer approval. Pumps are also hydrostatically tested per NFPA 20 at no less than 250 psi.

Fire Pump Feature Selector

Standard

- Bronze fitted pump construction
- Bronze shaft sleeves
- Bronze case wearing rings
- Dynamically balanced impellers
- Stainless steel impeller key
- Carbon steel shaft
- Corrosion-resistant lantern rings*
- Bronze stuffing box bushings
- Bronze or stainless steel glands
- Interwoven graphite-impregnated T.F.E. packing rings
- Cast integral bearing arms (most models)
- Regreaseable ball bearings
- Double row thrust bearing (outboard side)
- Upper casing lifting lugs
- Water slingers and grease seals
- Hydrostatic and Certified Performance test**
- Coupling guard
- Suction and discharge gauges with shutoff cocks
- Automatic air release valve
- Casing relief valve (electric driven units only)

Optional

- Ductile iron casings (available in selected 1800 and 1900 models)
- Some models available in 316 SST, duplex and super duplex
- Right- or left-hand rotation
- Impeller wearing rings
- Stainless steel shafts
- Double row ball bearings on inboard side
- External bypass line from casing to stuffing boxes (optional on Model 1800s and 1900s, standard on Model 2800s and 5800s)
- Formed steel drip-rim base (horizontal electric driven units only)
- 15' Suction lift test to verify performance at 150% of rated flow
- Available accessories include valves, headers, main relief valves, increasers and reducers, waste cones, and more.

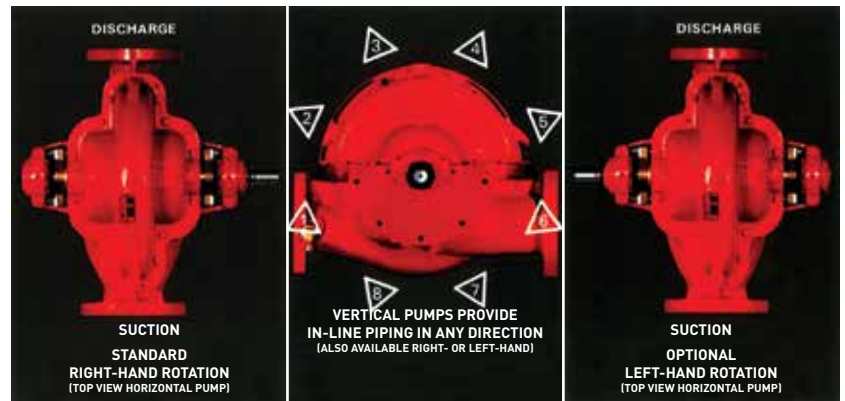

* Standard on Model 2800s and 5800s; furnished when suction pressure is below 40 psi on Model 1800s and 1900s.

** Test is performed with positive suction pressure.

Authorized Distributor:

www.trimcorph.com

TRIMCOR

TRIUMPH MACHINERY CORPORATION
THE PUMP, MOTOR & DRIVES SPECIALIST