

Pioneering for You

wilo

Wilo Philippines – 60 Hz

Drainage and Sewage Pumps

Pumps and pump systems for drainage and sewage, waste water collection, transport and dewatering.



Pioneering for You.

Our promise to you.

WILO SE is one of the world's leading premium suppliers of pumps and pump systems for building services, water management, and the industrial sector. With over 7800 employees in more than 60 subsidiaries around the world, we develop smart solutions that connect people, products and services to effectively support you in your daily work. "Pioneering for You" is our lasting commitment to clear customer focus, unrelenting pursuit of quality and our special passion for technology.

As the digital pioneer of the pumps industry, we understand the challenges that will shape the future. As an innovation and technology leader, we provide holistic solutions to address them. We know that these issues play a major role in your daily work and, in turn, ours too.

Sustainably better.

One of the most pressing tasks in times of limited natural resources is the responsible consumption of water, a resource that is becoming increasingly scarce. Efficiency, connectivity and safety will become increasingly important in the future. We aspire to offer you sustainable, user-friendly and high-performance solutions for building services and water management that are ahead of their time. We work closely with our customers to create innovative products and systems that perfectly match their requirements and are rounded off with convenient services. The result is integrated solutions you can rely on at all times.



DISCOVER WILO SOLUTIONS.

WILO offers a wide variety of intelligent pumps and systems to make our users' everyday lives simply more pleasant. Our energy-efficient solutions are suitable for residential, public and commercial properties. Wilo products are used in heating, air conditioning, cooling and water supply applications as well as for drainage and sewage..



HEATING, AIR CONDITIONING, COOLING

Wilo delivers individual solutions and highly efficient technology for applications in heating, air conditioning, cooling and domestic hot water.

WATER SUPPLY

Innovative products and systems from Wilo support applications in rainwater utilisation, water supply and pressure boosting, firefighting and raw water intake.

DRAINAGE AND SEWAGE

Wilo pumps and lifting units ensure safe and reliable operation in wastewater and sewage disposal.



DRAINAGE AND SEWAGE

Drainage Pump Structure

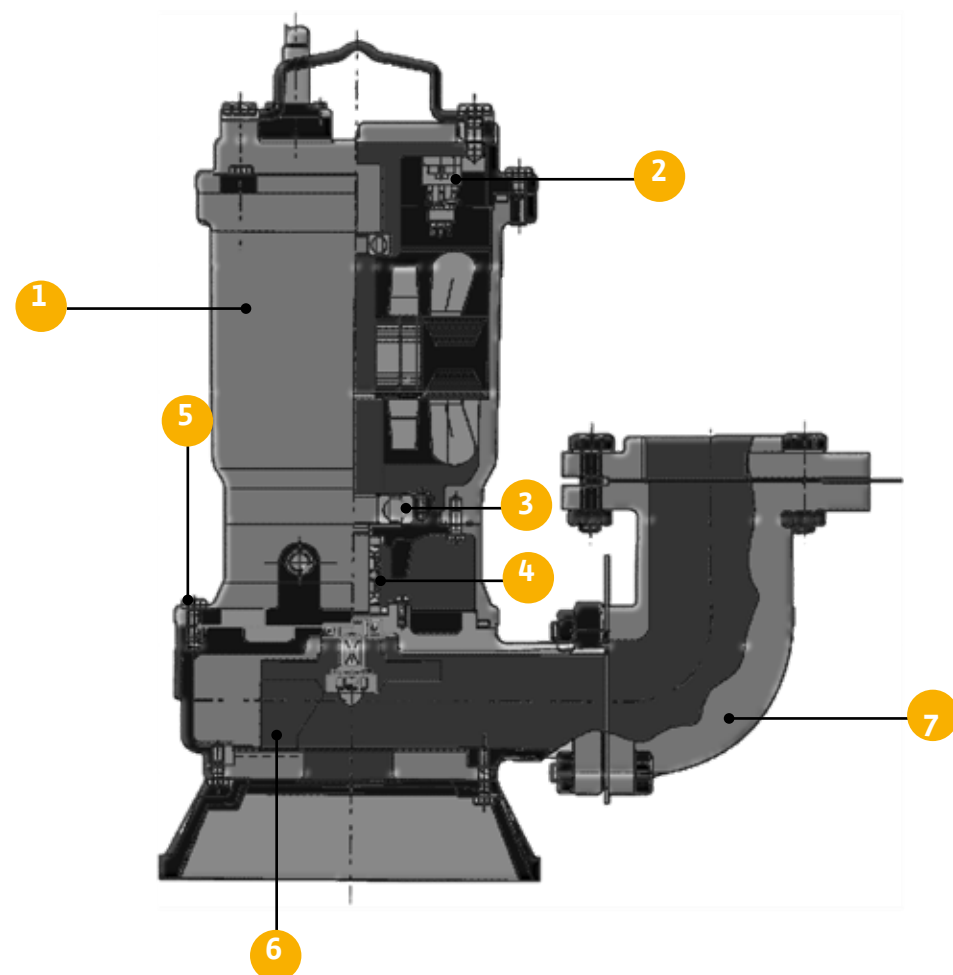

1. Motor

→ Submersible motor

2. O.L.P. or T.P

→ Overload protection or thermal protection

3. Bearing

→ Bearings

4. Mechanical Seal

→ Double mechanical seal
→ Motor: Ceramic and carbon
→ Pump: Sic and Sic

5. Bolts & Nuts

→ Stainless steel bolts and nuts

6. Impeller

→ Volute : Drainage
→ Vortex/Non-clog/cutter: waste water

7. Elbow & Auto Guide Rail System

Elbow and auto coupling device
AD-50 - 150
AD-50-500
→ PD(V)-A(S) Series
→ PD-G Series
→ PD-200/350 Series
→ PH-H751 Series
→ PDV-270 Series
→ DLV-270 Series
→ TS32/10.TS40/13 Series

Contractor's Pump Structure

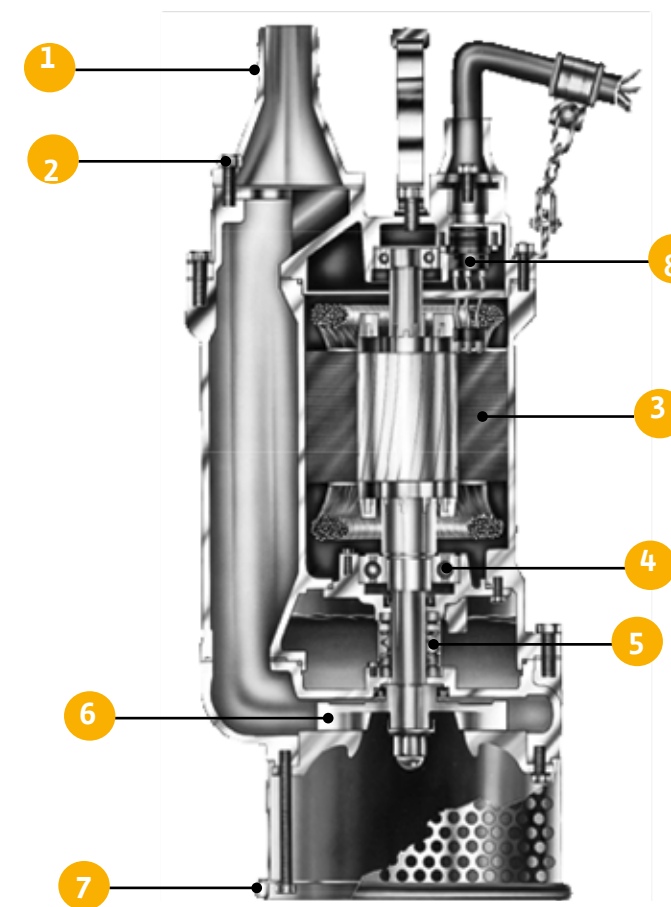

1. Hose of Flange Coupling

Hose or flange connection
→ DN50-150

2. Bolts & Nuts

→ Stainless steel bolts and nuts

3. Motor

→ Submersible motor

4. Bearing

→ Bearings

5. Mechanical Seal

→ Double mechanical seal
→ Motor: Ceramic and carbon
→ Pump: Sic and Sic

6. Impeller

→ Semi-open type impeller

7. Bottom Plate

→ Strainer and bottom plate

8. Over Load Protector (O.L.P)

→ Overload protection as an option

PD/TS Series

80W-950W-Volute Type



PD-200, 300, 550 760 M(A/LA)

Features

- Minimum residual water-level.
- Integrated motor cooling
- Weight lightning and easy transportation
- Double sealing system (Mech seal & oil seal)

Application

- Drainage for water tank, basement and handy sewage facility, general usages, wastewater treatment, construction site agriculture and flood control.



PD-A401, PD-S401, PDS75, PD-401 (M/MA/MLA)

Features

- Powerful performance
- Stainless steel shaft.
- Perfect sealing with double mechanical seal and oil seal.
- Thermal protection.

Application

- General drainage.
- Drainage form building basement & flood control.
- Drainage for construction site.



PD-G050 (M/MA)

Features

- Corrosion resistance for all wet parts.
- Minimum residual water-level.
- Portable usage due to lifting handle
- Easy removable strainer for cleaning dirt particles

Application

- Drainage for water tank in building and aquarium.
- Drainage for basement and residual water.
- Sewage from sink.

PD/TS Series

Performance Curve

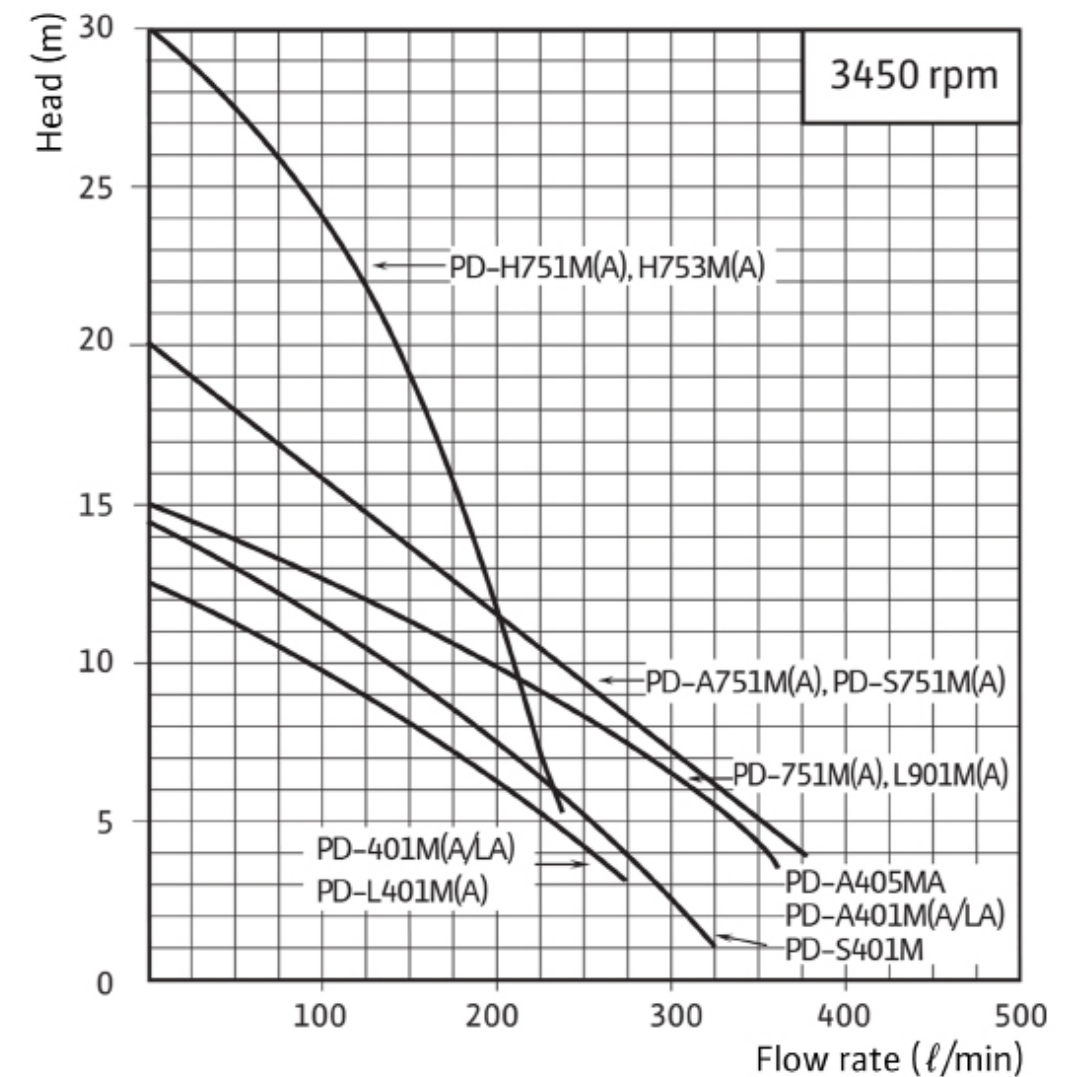
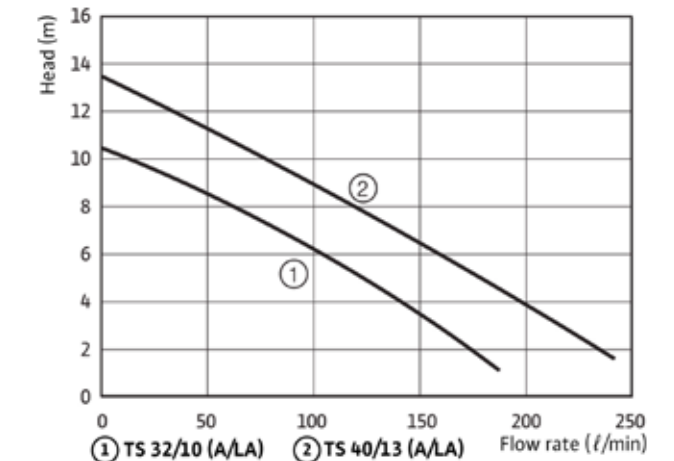
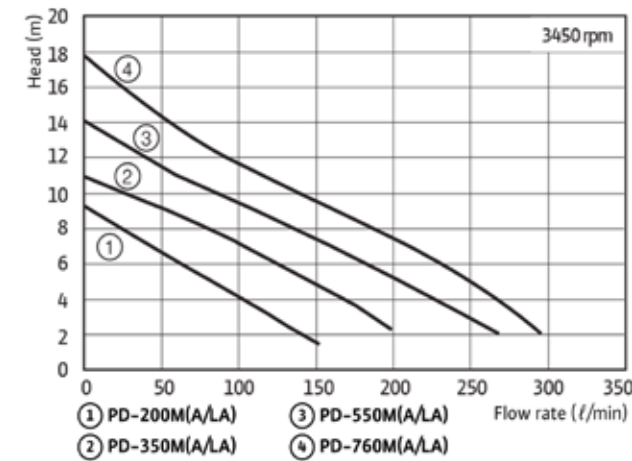

PD/TS Series

Technical Data

Model	Power Source	Output (W)	Discharge (mm)	Auto Coupling	Head (m)	Flowrate (l/min)	Max. Head	Max. Flowrate (l/min)	
PD-200M(A/LA)	Single Phase 220V 60Hz	200	20, 25, 32, 1 1/4"	-	1	130	9	140	
PD-350M(A/LA)		350	25, 32, 1 1/4"		1	180	11	190	
PD-550M(A/LA)		700	50(2")		7	145	14	250	
PD-760M(A/LA)		1,100	50(2")		7	200	18	300	
PD-S401M		600	50(2")		-	7	200	14	290
PD-S751M(A)		950					300	18	370
PD-A401M(A/LA)		600					200	13	290
PD-A751M(A)		950					250	18	370
PD-401M(A/LA)		400					40(1 1/2")	AD-50	7
PD-L401M(A)			-						
PD-405M(A)		950	50(2")		AD-50	7	250	14	350
PD-751M(A)					-				
PD-L901M(A)		950	40(1 1/2")		-	20	120	28	230
PD-H751M(A)				50(2")					
PD-H753M(A)		80	20,25 (1")	-	-	-	5	70	
PD-G050M/MA			350	-	-	-	10	175	
TS 32/10(A/LA)			600	40 (1 1/2")	-	-	-	13	220
TS 40/13 (A/LA)									

PD-200/350M(A)

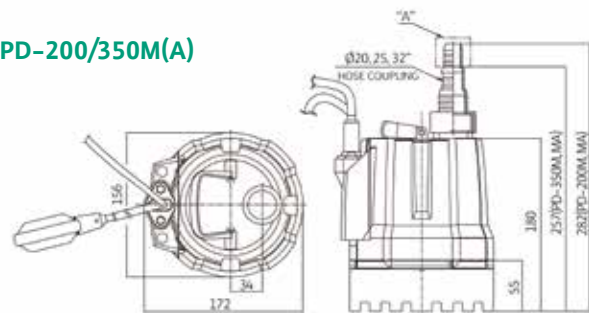

PD-200/350MLA

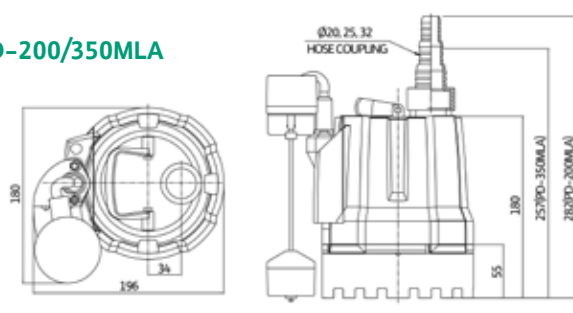

PD-550/760M(A)

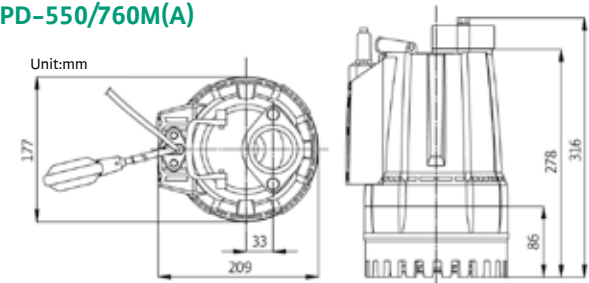

PD-550/760MLA

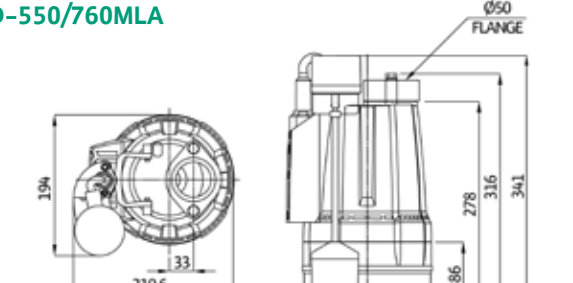

PD/TS Series

Technical Data

PD-A401M, A751M(A)

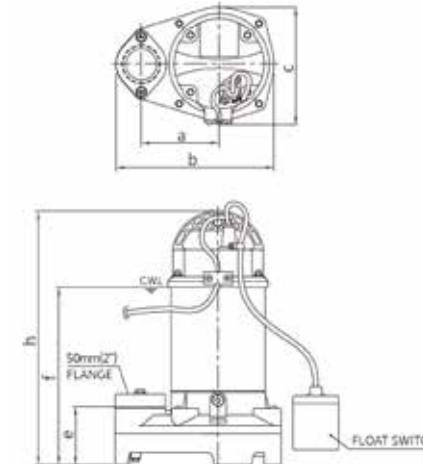

PD-S401M, S751M(A)

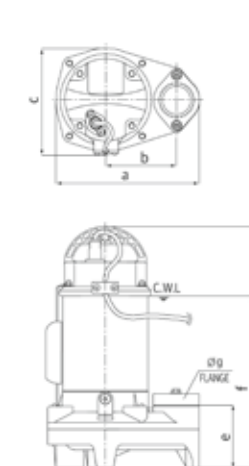

PD-401M(A/LA), L401M(A), 405M(A)
751M(A), L901M(A)
PD-H751M(A), H753M(A)

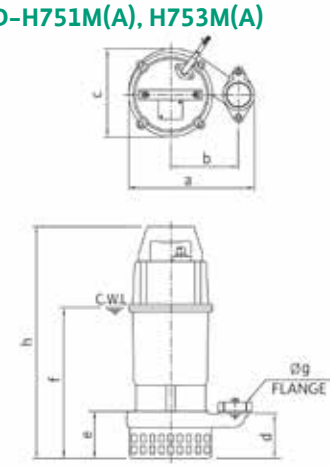

PD-G050M(MA)

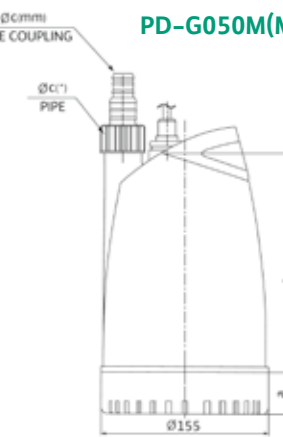

TS 32/10, 40/13(A/LA)

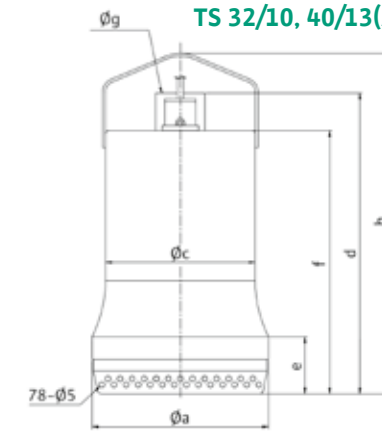

Model	(φ)a	b	φc	d	e	f	φg	h
PD-S401M	245	121	182	-	86	273	50	390
PD-S751M(A)						290		407
PD-A401M(A/LA)	245	121	182	-	86	273	50	390
PD-A751M(A)						290		407
PD-401M(A/LA)	248	130	171	93	102	283	40	425
PD-L401M(A)						280		406
PD-405M(A)						293		425
PD-751M(A)	248	124	179	-	100	298	50	458
PD-L901M(A)						304		430
PD-H751M(A)	233	116	179	-	100	280	40	440
PD-H753M(A)	248	124	179	-	100	280	50	440
PD-G050M/MA	34.5	200	20,25 (hose) 25 (1", Pipe)	-	-	-	-	-
TS 32/10(A/LA)	161	-	136.5	280	53	246	32	317
TS 40/13 (A/LA)	171	-	146.5	304	77	269	40	344

PD Series

1.5~15KW - Volute Type



PD-Series (1.5~15kW)

Features

- Powerful performance up to max head (21m) and flow rate (l 550) in 2HP range.
- Stainless steel shaft.
- Perfect selling wit double mechanical seal and oil seal.
- Thermal protection.

Performance Curve

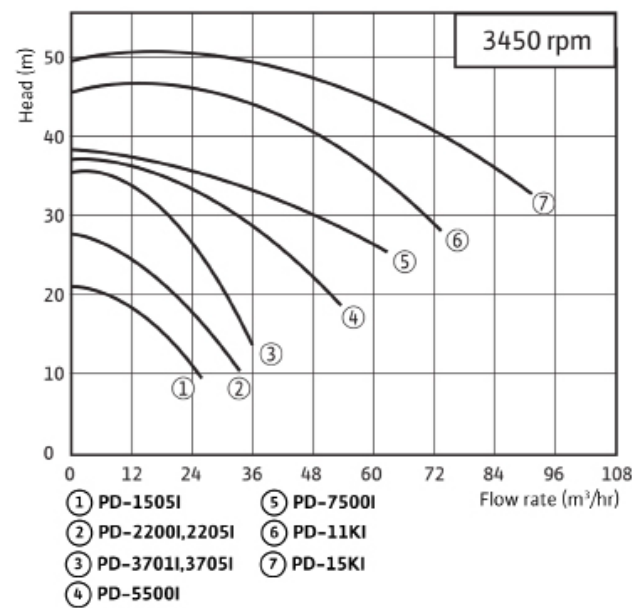

Application

- General drainage with solids (solid size: under strainer suvtion bore)
- Drainage for waste water treatment and small disposal facility.
- Drainage for small fountain and artificial water falls.
- Drainage for agriculture and horticulture.
- Drainage for underground commercial facility, building basement, mahine room and sanitation as well as under-ground leachate.

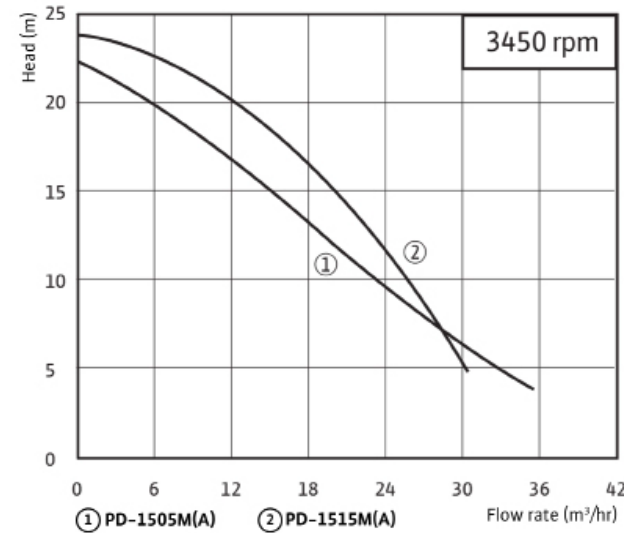

PD Series

Technical Data

Model	Power Source	Output (W)	Discharge (mm)	Auto Coupling	Head (m)	Flowrate (m/h)
PD-1505M(A)	Single Phase 220V, 60Hz	1.5(2HP)	Ø80(3")	-	10	350
PD-1515M(A)			Ø50(2")	AD-50	14	300
PD-1505I	3상 380V 60Hz	1.5(2HP)	Ø50(2")	AD-50	17	15
PD-2200I			Ø80(3")	AD-65/80	21	18
PD-2205I		Ø65				
PD-3701I		3.7(5HP)	Ø80(3")	AD-80	25	36
PD-3705I			Ø65			
PD-5500I		5.5(7.5HP)	Ø80(3")	AD-80	25	36
PD-7500I		7.5(10HP)	Ø100(4")	AD-100	30	48
PD-11KI		11(15HP)			33	66
PD-15KI		15(20HP)			40	72

PD-1505M(A)

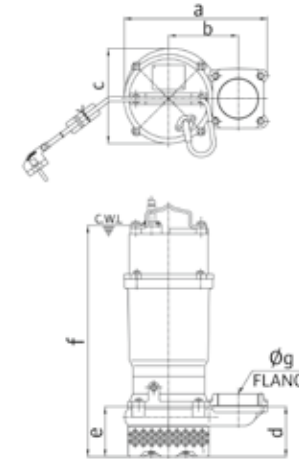

PD-1515M(A)

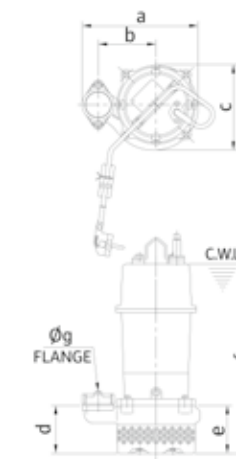

PD-1505I

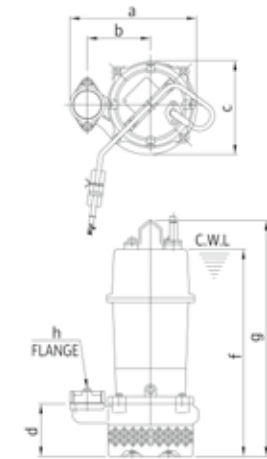

PD-2200I, 2205I

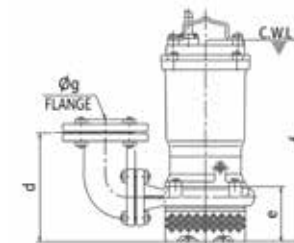

PD-3701I,3705I

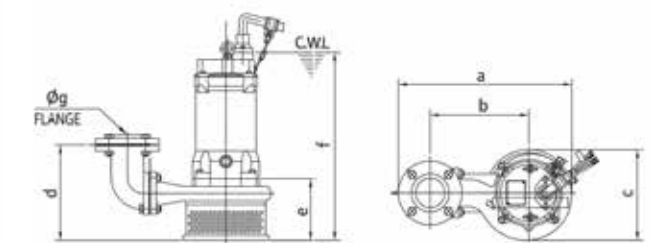

PD Series

Technical Data

PD-5500I

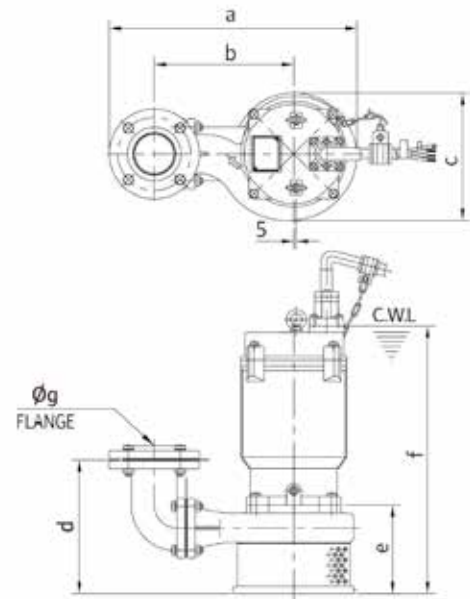

PD-7500I

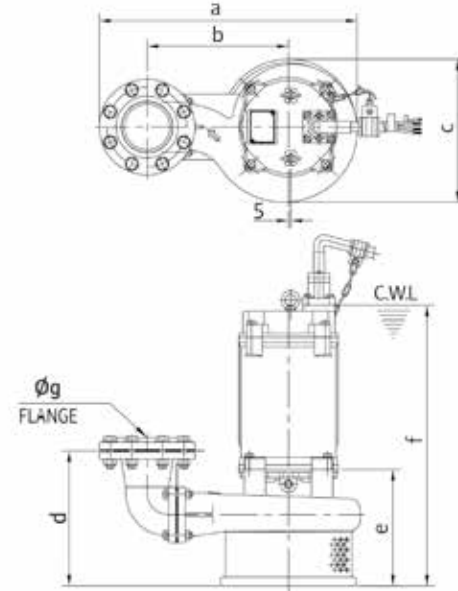

PD-11KI, 15KI

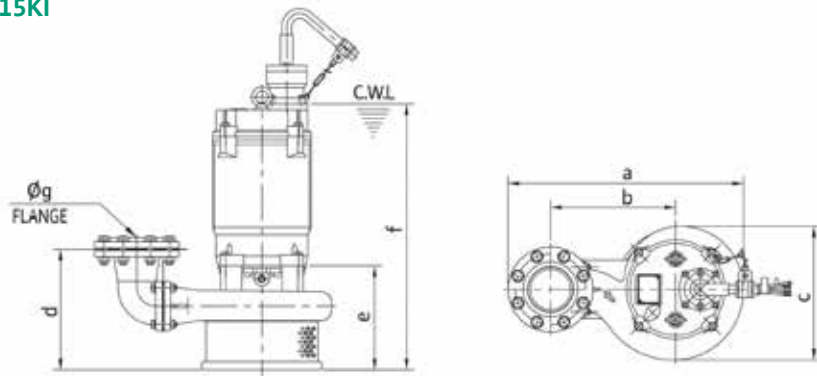

Model	a	b	Øc	d	e	f	Øg
PD-1505M(A)	313	150	205	108	108	425	80
PD-1515M(A)	261	130	193	108	108	425	50
PD-1505I	261	130	193	108	108	425	50
PD-2200I	412	218	212	236	119	429	80
PD-2205I	412	218	212	236	119	429	65
PD-3701I	499	286	262	276	178	513	80
PD-3705I	499	286	262	276	178	513	65
PD-5500I	509	286	262	274	181	549	80
PD-7500I	566	310	314	296	256	616	100
PD-11KI	583	310	330	297	257	657	
PD-15KI						707	

PDV/PDX Series

300~30KW - Vortex Type

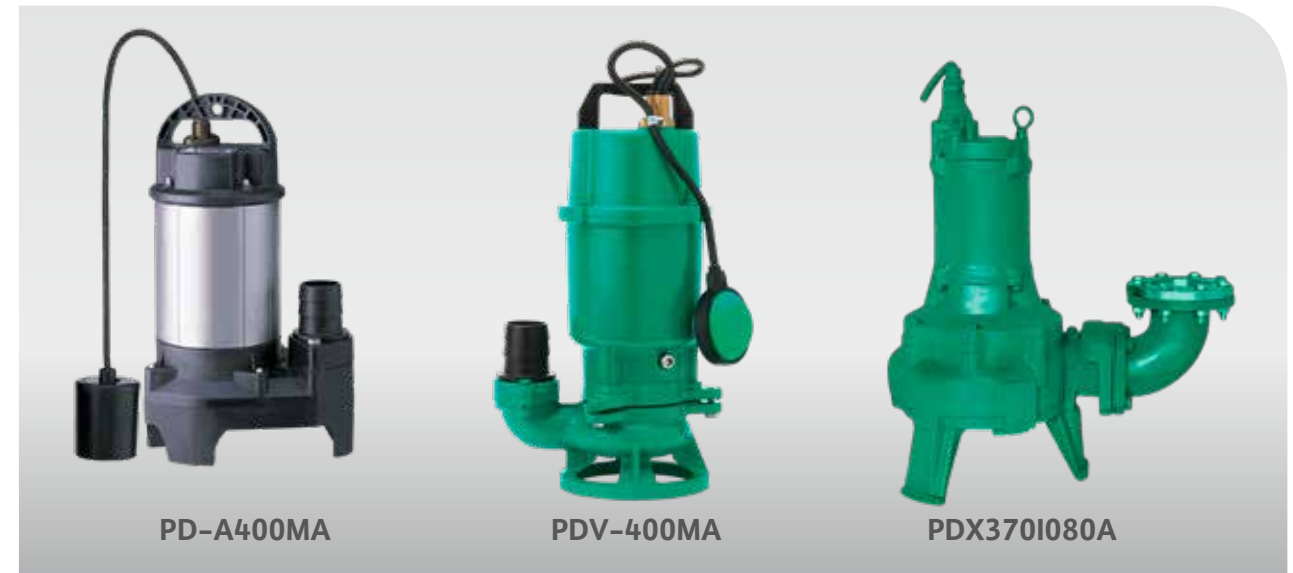

PDV/PDX-Series

Features

- Stainless steel and engineering plastic materials
- Easy transportation and installation.
- Triple sealing design with packing
- Applying double mechanical seal made of silicon carbide and oil seal.

Application

- Drainage and sewage for basement.
- Drainage and sewage for wastewater from farms as well as human waste.
- Drainage and sewage for wastewater and sewage treatment.
- Wasterwater transport with solida content.

Performance Curve

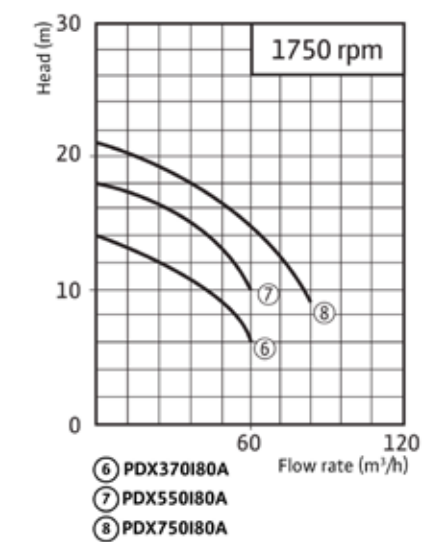
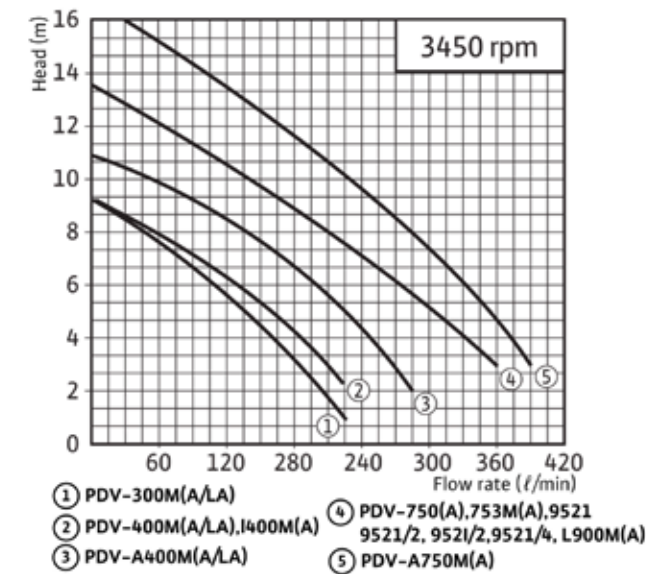

PDV/PDX Series **Technical Data**

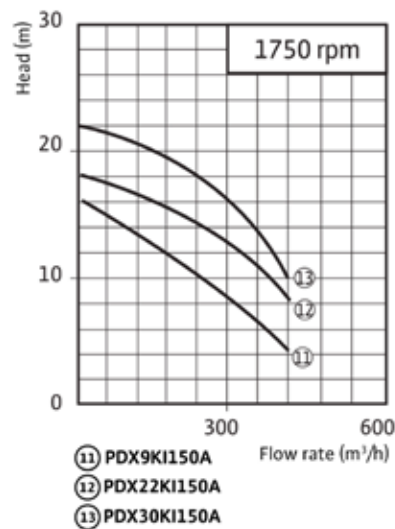
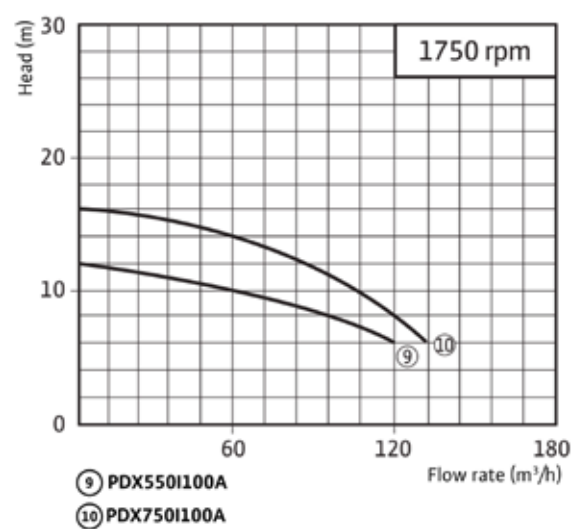

Model	Power Source	Output (kW)	Discharge (mm)	Auto Coupling	Head (m)	Flowrate (l/min)	Speed (rpm)	
PDV-A400M(A/LA)	Single Phase 220V 60Hz	0.6(4/5HP)	Ø50(2")	-	6	180	3450	
PDV-A750M(A)		0.95(1 1/4HP)				300		
PDV-300M(A/LA)		0.3(2/5HP)	Ø32(1 1/4")		3	145		
PDV-400M(A/LA)		0.4(1/2HP)	Ø50(2")		AD-50	6		130
PDV-L400M(A)								250
PDV-750M(A)								250
PDV-753M/754M(A)								250
PDV-L900M(A)	3 Phase 380V 60Hz	0.95(1 1/4HP)	Ø50(2")	AD-50	6	250	3450	
PDV-952I, 952I/2, 952I/4						250		

Model	Power Source	Output (kW)	Discharge (mm)	Auto Coupling	Head (m)	Flowrate (m³/h)	Speed (rpm)
PDX370I080A	3 Phase 380V 60Hz	3.7(5HP)	Ø80(3")	ADD-80	9	48	1750
PDX550I080A		5.5(7.5HP)			13	48	
PDX750I080A		7.5(10HP)			16	51	
PDX550I100A		5.5(7.5HP)	Ø100(4")	ADD-100	8	96	
PDX750I100A					7.5(10HP)	11	
PDX19KI150A		18.5(25HP)	Ø150(6")	ADD-150	10	240	
PDX22KI150A					14	240	
PDX30KI150A					18	240	

PDV/PDX Series **Technical Data**

PDV-A400M(MA/MLA)

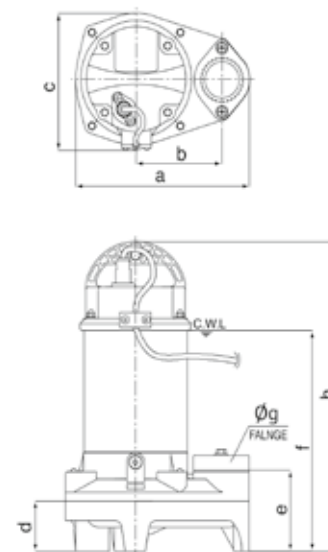

PDV-400M(MA/MLA)

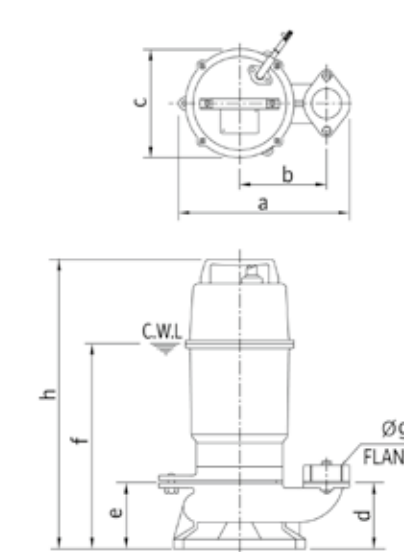

PDX Series

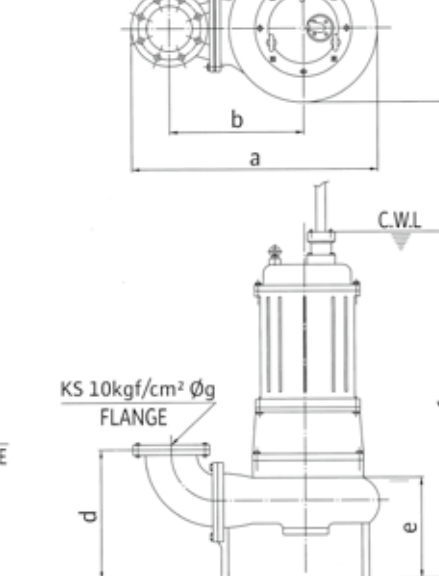

Model	a	b	c	d	e	f	Øg	h
PDV-A400M(A/LA)	245	121	182	60	106	293	50	411
PDV-A750M(A)						310		428
PDV-300M(A/LA)	202	96	140	87	77	266	32	390
PDV-400M(A/LA)	252	120	165	95	95	303	50	445
PDV-L400M(A)			145			300		420
PDV-750M(A), 753M, 754M(A)			165			318		468
PDV-L900M(A)			145			325		450
PDV-952I, 952I/2, 952I/4	534	320	280	232	314	634	80	-
PDX370I080A			300			743		
PDX550I080A	562	340	344	264	226	778	100	-
PDX750I080A	612							
PDX550I100A	863	500	446	400	320	1059	150	-
PDX19KI150A								
PDX22KI150A								
PDX30KI150A								

DLV Series

0.95~15kW - Non-Clog & Cutter Type



Performance Curve

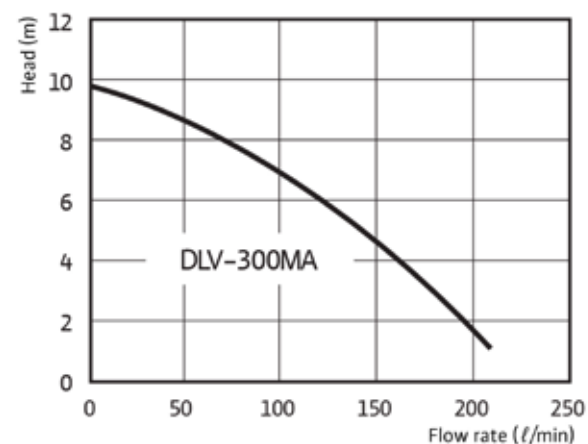

DLV-300MA

Features

- Odor-free due to perfect sealing a tank with silicon gasket.
- Space saving design.
- Easy maintainabce with avortex type (free passage).
- Sewage lifting unit.

→

Application

- Disposal of sewage that cannot be discharge naturally to the sewer system.
- Disposal of sewage in a (semi) basement for residential and industrial purposes.

Model	Power Source	Output (W)	Discharge (mm,inch)	Head (m)	Flowrate (l/min)	Operating Volume (l)
DLV-300MA	Single Phase 220V, 60Hz	300	∅32 (1 1/4")	9	200	23

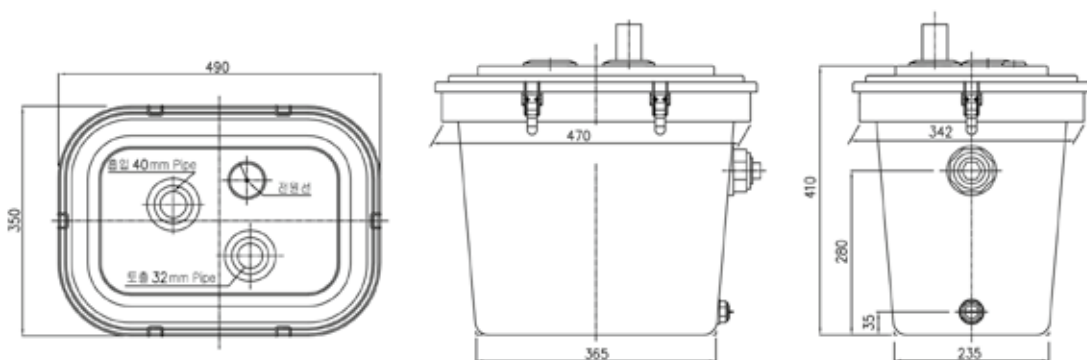

PDN/PDV/PDC Series

0.95~15kW - Non-Clog & Cutter Type



PDN/PDV/PDC-Series

Features

- Leak proof by double mechanical seal and oil seall.
- Motor protection by thermal protector.
- Excellent sludge transfer by non clog type.
- Safety design with built-in overload protection.
- Variuos materials are available.

Application

- Drainage for waste water factories and waste treatment plant.
- Delivery of sewage at sewage treatment plant, human waste treatment.
- Drainage for buildings.
- Treatment utility drainage.

Performance Curve

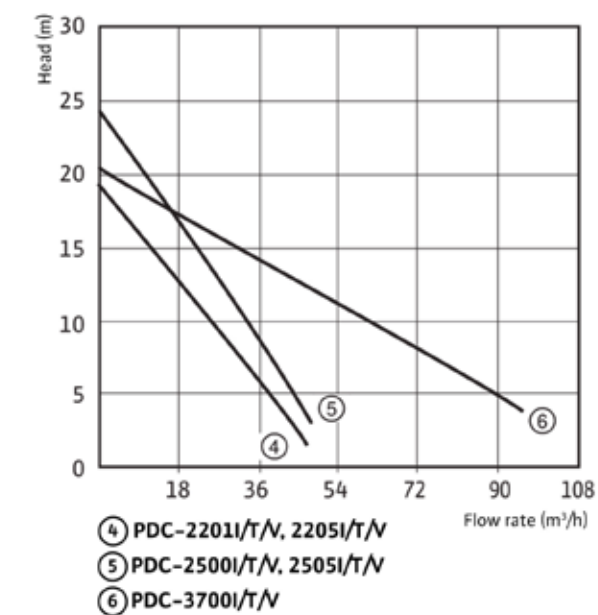
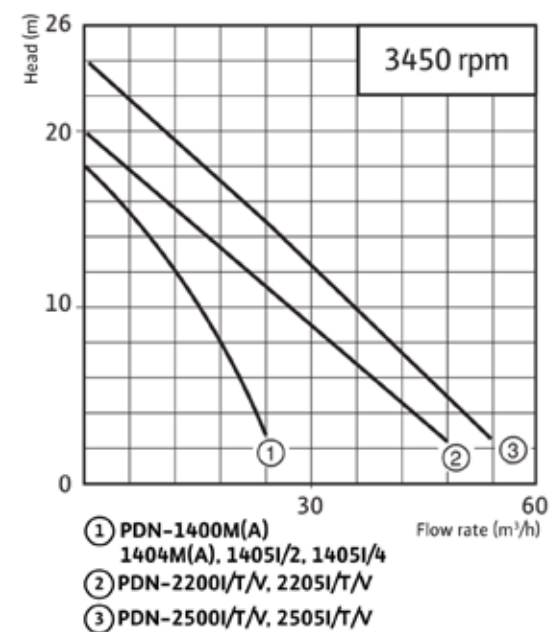

PDN/PDV/PDC Series

Technical Data

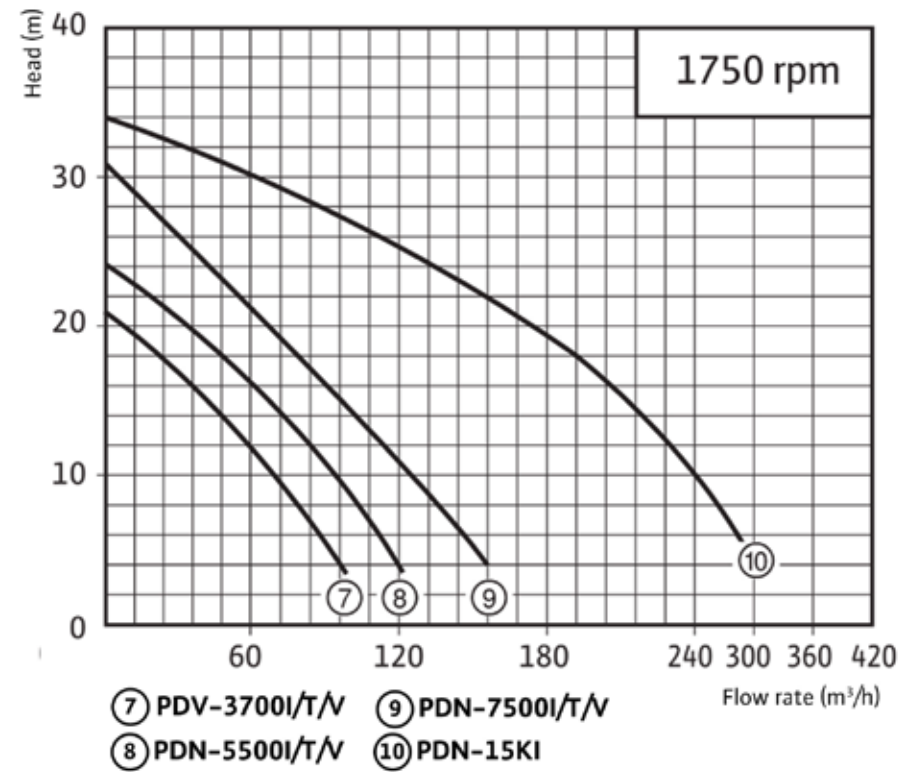

Model	Power Source	Output (kW)	Discharge (mm)	Auto Coupling	Head (m)	Flowrate (m ³ /h)	Speed (rpm)	
PDN-1400M(A)	Single Phase 220V 60Hz	0.95(1 1/4HP)	Ø50(2")	AD-50	7	18	3450	
PDN-1404M(A)								
PDN-1405I, 1405I/2, 1405I/4	3 Phase, 60Hz 380/220/440V	1.5(2HP)	Ø80(3")	AD-65/80	10	26.4	3450	
PDN-2200I/T/V			Ø65					
PDN-2205I/T/V			Ø80(3")					
PDC-2201I/T/V		Ø65	24					
PDC-2205I/T/V		Ø80(3")	36					
PDN-2500I/T/V		Ø65	12		30			
PDN-2505I/T/V		2.2(3HP)	Ø80(3")	10	33			
PDC-2500I/T/V			Ø65	11	30			
PDC-2505I/T/V			Ø80(3")	12	54			
PDV-3700I/T/V		3.7(5HP)	Ø80(3")	AD-80/100	16	60		1750
PDC-3700I/T/V								
PDN-5500I/T/V		5.5(8HP)	Ø100(4")	AD-80/100	18	75		
PDN-7500I/T/V								
PDN-15KI/T		3 Phase, 60Hz 380/230V	15(20HP)	Ø150(6")	AD-150	22		150

PDN/PDV/PDC Series

Technical Data

PDN-1400M(A), 1404M(A), 1405I, 1405I/2, 1405I/4

PDN-2200I/T/V, 2205I/T/V, 2500I/T/V, 2505I/T/V, PDC-2201I/T/V,

PDV-3700I/T/V, PDC-3700I/T/V

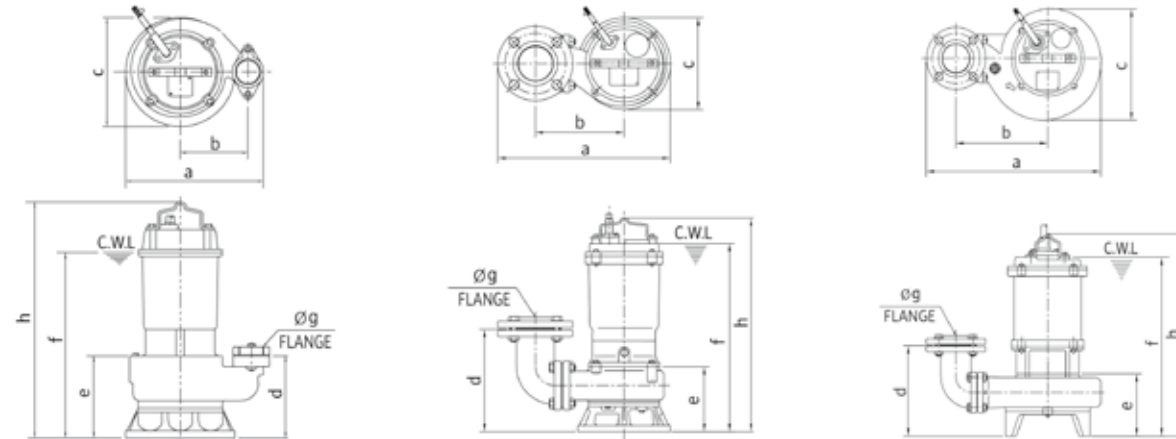

PDN-5500I/T/V, 7500I/T/V

PDN-15KI

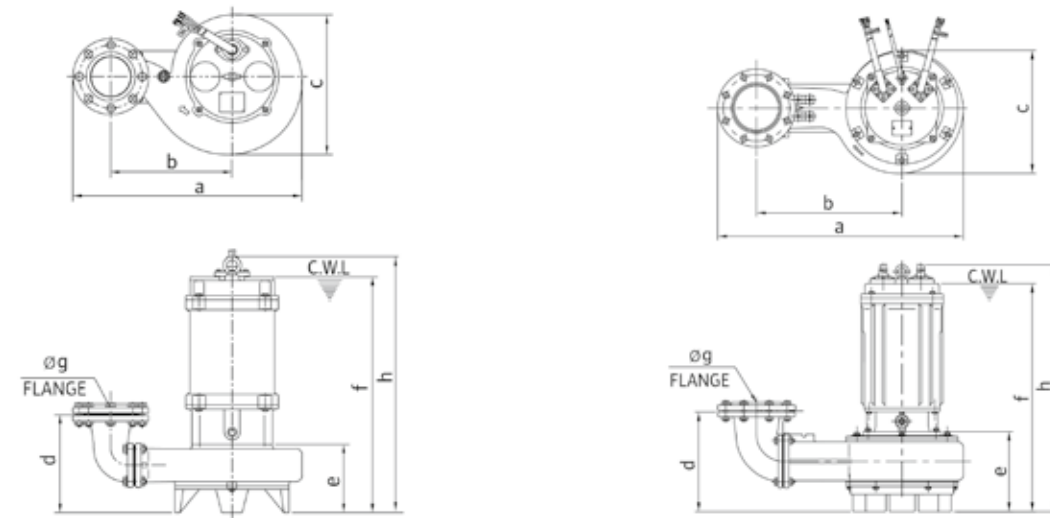

Model	a	b	c	d	e	f	Øg	h
PDN-1400M(A), 1404M(A)	261	130	193	139	139	335	50	495
PDN-1405I, 1405I/2, 1405I/4						345		443
PDN-2200I/T/V, PDC-2201I/T/V	426	219	228	254	160	468	80	530
PDN-2500I/T/V, PDC-2500I/T/V								
PDN-2205I/T/V, PDC-2205I/T/V	420	218	228	254	160	458	65	520
PDN-2505I/T/V, PDC-2505I/T/V								
PDV-3700I/T/V, PDC-3700I/T/V	546	287	332	270	187	514	80	565
PDN-5500I/T/V	636	337	388	271	189	654	100	710
PDN-7500I/T/V								
PDN-15KI/T	894	530	448	365	277	830	150	890

PDG Series

11~75kW - Non-Clog



PDG Series

Features

- Easy maintenance by auto discharge connector
- Minimize stopping-up of foreign materials
- Various materials are available.

Application

- Drainage and sewage in industrial application.
- Drainage and sewage for waste/sewage water treatment.
- Drainage and sewage for building facility.
- Drainage for combined treatment process.
- Flood control

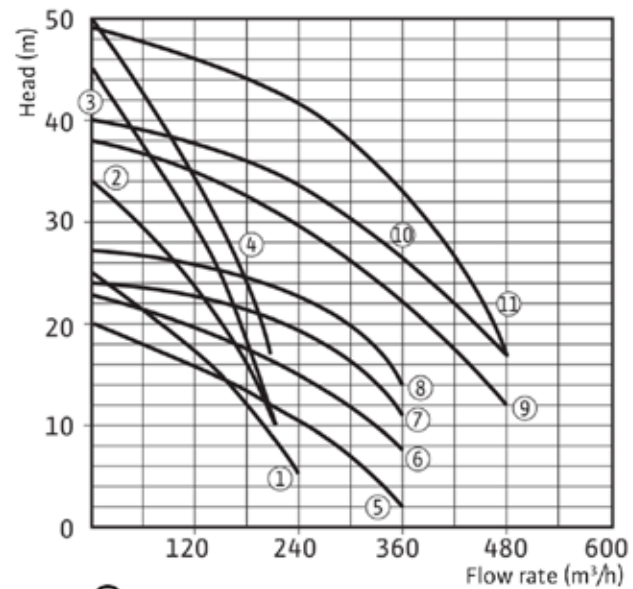

- ① PDG11KI150A
- ② PDG15KI150A
- ③ PDG22KI150A
- ④ PDG30KI150A
- ⑤ PDG11KI200A
- ⑥ PDG15KI200A
- ⑦ PDG22KI200A
- ⑧ PDG30KI200A
- ⑨ PDG37KI200A
- ⑩ PDG45KI200A
- ⑪ PDG55KI200A

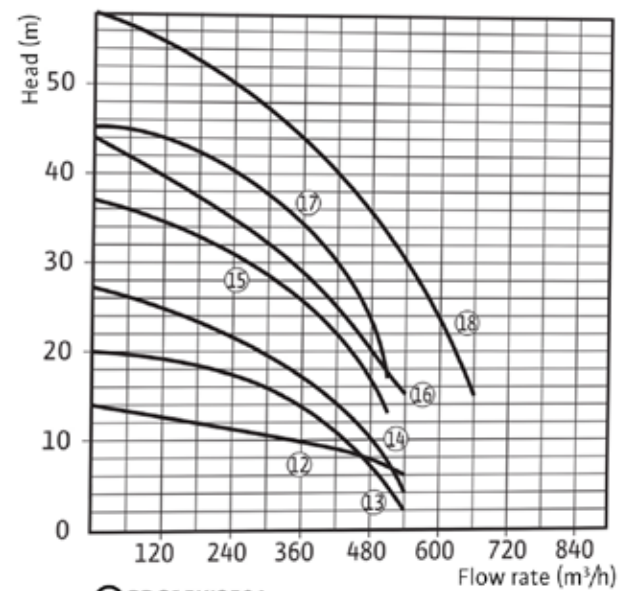

- ⑫ PDG15KI250A
- ⑬ PDG22KI250A
- ⑭ PDG30KI250A
- ⑮ PDG37KI250A
- ⑯ PDG45KI250A
- ⑰ PDG55KI250A
- ⑱ PDG75KI250A

PDG Series

Technical Data

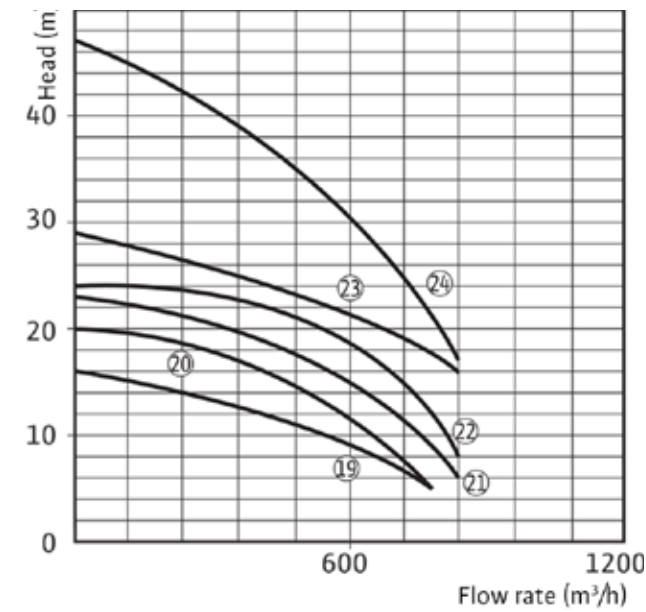

- ⑲ PDG22KI300A
- ⑳ PDG30KI300A
- ㉑ PDG37KI300A
- ㉒ PDG45KI300A
- ㉓ PDG55KI300A
- ㉔ PDG75KI300A

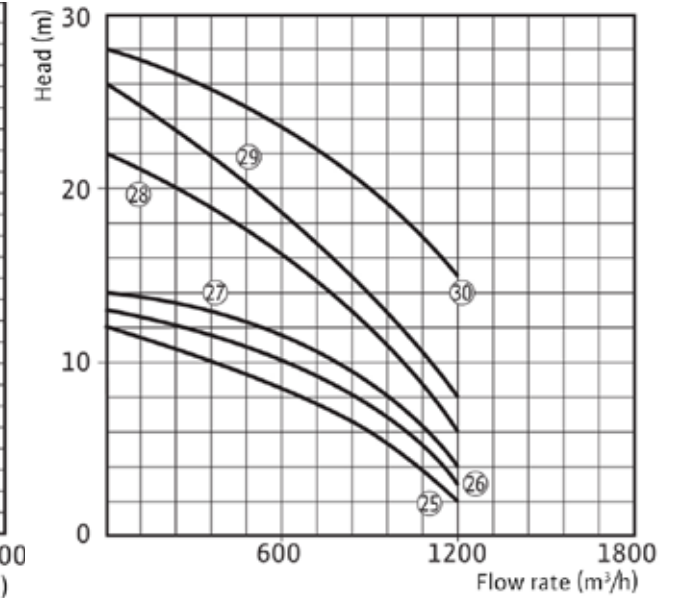

- ㉕ PDG22KI350A
- ㉖ PDG30KI350A
- ㉗ PDG37KI350A
- ㉘ PDG45KI350A
- ㉙ PDG55KI350A
- ㉚ PDG75KI350A

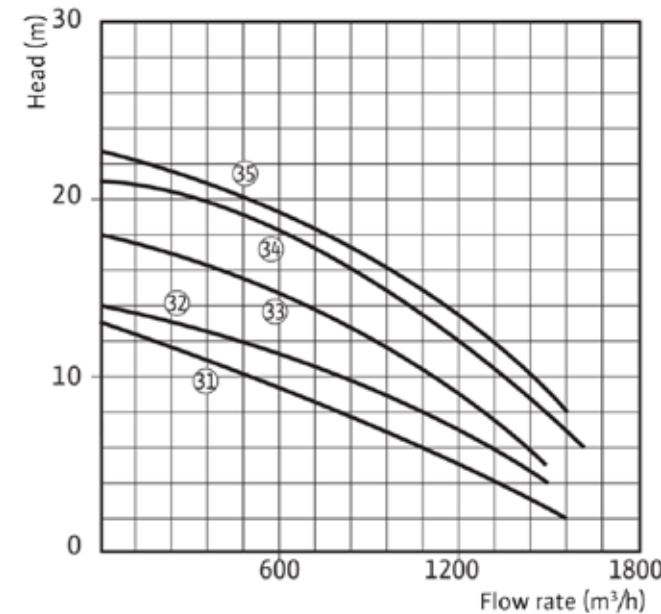

- ㉓① PDG30KI400A
- ㉓② PDG37KI400A
- ㉓③ PDG45KI400A
- ㉓④ PDG55KI400A
- ㉓⑤ PDG75KI400A

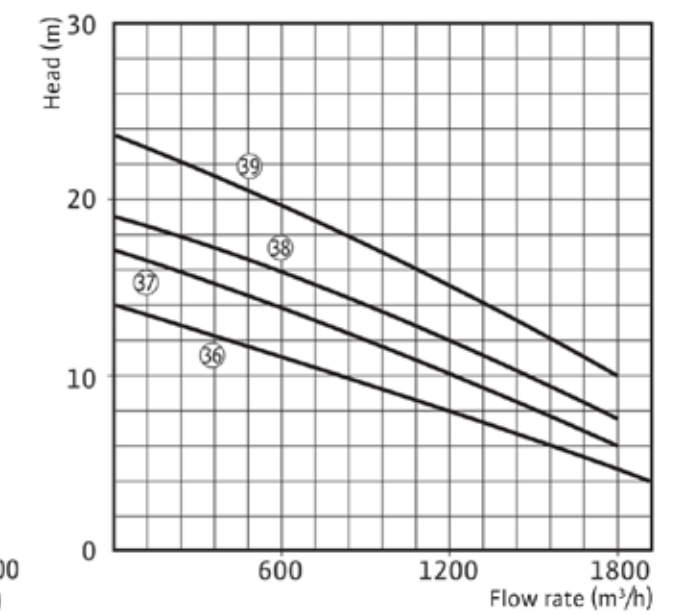

- ㉓⑥ PDG37KI500A
- ㉓⑦ PDG45KI500A
- ㉓⑧ PDG55KI500A
- ㉓⑨ PDG75KI500A

PDG Series

Technical Data

Model	Power Source	Output (kW)	Discharge (mm)	Head (m)	Flowrate (m ³ /h)	Speed (rpm)
PDG11KI150A	3 Phase 380V 60Hz	11	150	15.0	150	1750
PDG15KI150A		15				
PDG22KI150A		22				
PDG30KI150A		30				
PDG11KI200A		11	200	9.0	270	1750
PDG15KI200A		15				
PDG22KI200A		22				
PDG30KI200A		30				
PDG37KI200A		38				
PDG45KI200A		45				
PDG55KI200A		55	40.0			
PDG15KI250A		15	250	9.0	420	1150
PDG22KI250A		22		11.0		1750
PDG30KI250A		30		14.0		1750
PDG37KI250A		37		19.0		
PDG45KI250A		45		24.0		
PDG55KI250A		55		30.0		
PDG75KI250A		75	40.0			
PDG22KI300A		22	300	9.0	600	1150
PDG30KI300A		30		11.0		
PDG37KI300A		37		15.0		
PDG45KI300A		45	300	18.0	600	1150
PDG55KI300A		55		21.0		
PDG75KI300A		75		31.0		
PDG22KI350A		22		350		
PDG30KI350A		30	7.5			
PDG37KI350A		37	9.0			
PDG45KI350A		45	12.0			
PDG55KI350A		55	14.0			
PDG75KI350A		75	20.0			
PDG30KI400A		30	400	5.0	1200	850
PDG37KI400A		37		7.0		
PDG45KI400A		45		9.0		
PDG55KI400A		55		12.0		1150
PDG75KI400A		75	16.0	1200		
PDG37KI500A		37	500	5.0	1800	700
PDG45KI500A		45		6.0		
PDG55KI500A		55		7.5		850
PDG75KI500A		75		10.0		

PDG Series

Technical Data

Model	a	b	c	d	Øk	e	22f	Øg
PDG11KI150A	850	460	500	435	500	310	983	150
PDG15KI150A								
PDG22KI150A								
PDG30KI150A	940	500	600	470	600	430	1133	
PDG11KI200A	1010	582	456	460	500	320	1006	200
PDG15KI200A								
PDG22KI200A	1015	575	550	520		479	1198	
PDG30KI200A					550			
PDG37KI200A	1030	580	584	500		430	1301	
PDG45KI200A								
PDG55KI200A								
PDG15KI250A	1238	675	750	688	725	600	1279	250
PDG22KI250A	1075	600	550	560	545	480	1198	
PDG30KI250A								
PDG37KI250A								
PDG45KI250A	1182	655	653	600	552	480	1378	
PDG55KI250A								
PDG75KI250A								
PDG22KI300A	1348	795	820	665	552	510	1332	300
PDG30KI300A								300
PDG37KI300A								
PDG45KI300A	1430	795	820	665	552	510	1416	
PDG55KI300A							1516	
PDG75KI300A								
PDG22KI350A	1735	970	915	772	620	610	1446	350
PDG30KI350A								
PDG37KI350A							1644	
PDG45KI350A	1518	835	945	742	875	635	1733	
PDG55KI350A							1763	
PDG75KI350A								
PDG30KI400A								400
PDG37KI400A							1633	
PDG45KI400A	1593	875	945	875	875	720	1733	
PDG55KI400A							1963	
PDG75KI400A								
PDG37KI500A						840	2366	500
PDG45KI500A							2466	
PDG55KI500A	2093	1200	1100	1100	1050	790	2258	
PDG75KI500A							2466	

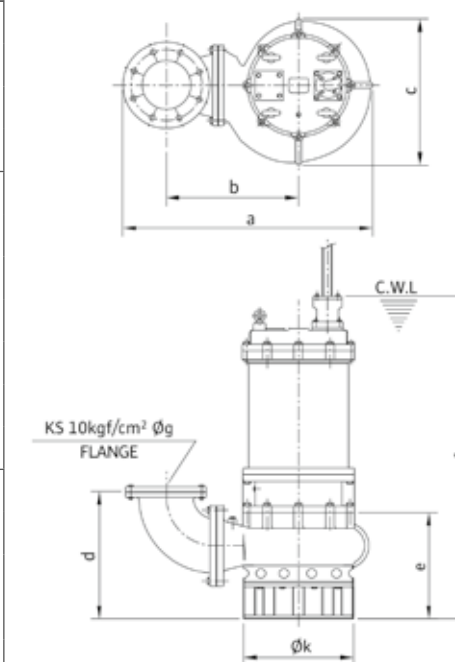

Auto Coupling Device (Ø50mm)

Auto Guide Rail System

AD-PDG Series

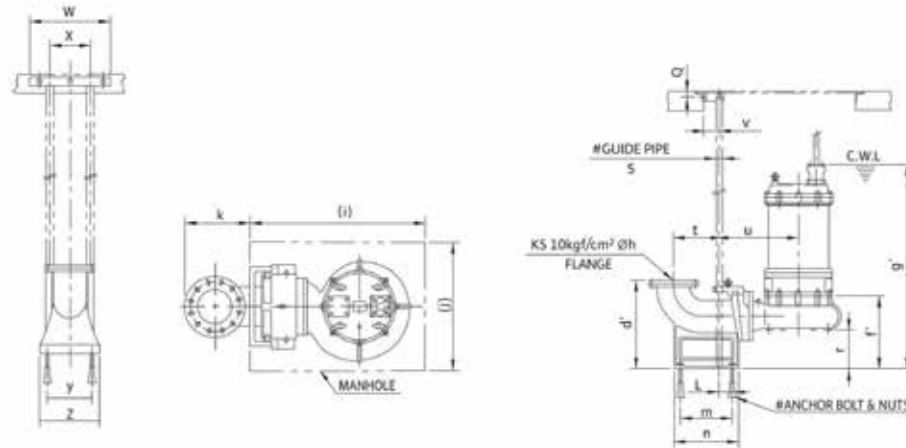

Model	Auto coupling	d'	f'	g'	Øh	(i)	(j)	k	L	m	n	Q	r	s	t	u	v	w	x	y	z
PDG11KI150A	ADD-150	480	400	1048	160	1200	850	330	95	300	415	80	215	40A	290	438	100	410	280	300	400
PDG15KI150A																					
PDG22KI150A																					
PDG30KI150A																					
PDG11KI200A	ADD-200	550	420	1078	200	1200	850	395	100	350	400	80	222	40A	330	524	100	410	300	300	400
PDG15KI200A																					
PDG22KI200A																					
PDG30KI200A																					
PDG37KI200A	ADD-250	630	450	1208	250	1400	1000	500	100	430	560	80	204	40A	400	519	100	410	280	360	460
PDG45KI200A																					
PDG55KI200A																					
PDG75KI200A																					
PDG15KI250A	ADD-300	810	470	1551	300	1500	1000	523	120	470	630	100	146	65A	450	770	150	700	490	500	600
PDG22KI250A																					
PDG30KI250A																					
PDG37KI250A																					
PDG45KI250A	ADD-350	880	443	1198	350	1600	1200	575	120	470	630	100	194	65A	480	870	150	700	490	520	640
PDG55KI250A																					
PDG75KI250A																					
PDG22KI300A																					
PDG30KI300A	ADD-400	1060	545	1451	400	1700	1200	760	100	550	960	100	1367	100A	650	895	170	910	550	600	750
PDG37KI300A																					
PDG45KI300A																					
PDG55KI300A																					
PDG75KI300A	ADD-500	1400	725	1636	500	2000	1500	938	110	800	1100	100	1736	100A	780	1100	180	1100	700	800	1000
PDG22KI350A																					
PDG30KI350A																					
PDG37KI350A																					
PDG45KI350A	ADD-400	1060	725	1736	400	1700	1200	760	100	550	960	100	1968	100A	650	895	170	910	550	600	750
PDG55KI350A																					
PDG75KI350A																					
PDG30KI400A																					
PDG37KI400A	ADD-500	1400	940	2260	500	2100	1600	938	110	800	1100	100	2360	100A	780	1100	180	1100	700	800	1000
PDG45KI400A																					
PDG55KI400A																					
PDG75KI400A																					
PDG37KI500A	ADD-500	1400	940	2176	500	2100	1600	938	110	800	1100	100	2360	100A	780	1100	180	1100	700	800	1000
PDG45KI500A																					
PDG55KI500A																					
PDG75KI500A																					

PDU Series

3.7~15kW-Light Duty



PDU Series

Features

- Top discharge arrangement allows easy access into areas with space limitations.
- Portable or permanent installation.
- Double Mechanical seals
- Light weight and thermal protection.

Application

- Drainage of tunnels, excavation pits, subway construction site, storm water and civil engineering works.
- Mobile use for contractors, installer and service industries.

Performance Curve

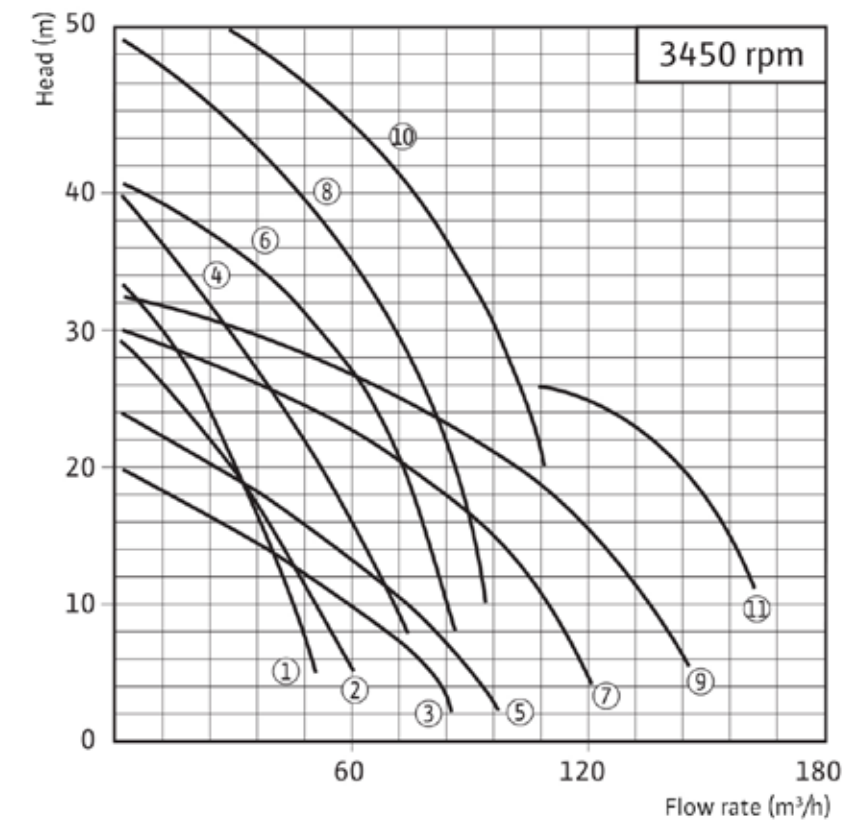

- | | |
|----------------|----------------|
| ① PDU-371IH(F) | ⑦ PDU-750IL(F) |
| ② PDU-371IM(F) | ⑧ PDU-11KI(HF) |
| ③ PDU-371IL(F) | ⑨ PDU-11KIL(F) |
| ④ PDU-550IH(F) | ⑩ PDU-15KI(HF) |
| ⑤ PDU-550IL(F) | ⑪ PDU-15KIL(F) |
| ⑥ PDU-750IH(F) | |

PDU Series

Technical Data

Model	Power Source	Output (kW)	Discharge (mm)	Head (m)	Flowrate (m³/h)	Bearing	
						Load Side	Half Load Side
PDU-371IH(F)	3 Phase 380V 60Hz	3.7 (5HP)	50	30	12	6307ZZ	6304ZZ
PDU-371IM(F)			80	20	30		
PDU-371IL(F)			100	10	60		
PDU-550IH(F)		5.5 (7.5HP)	80	25	36	6308ZZ	
PDU-550IL(F)			100	15	60		
PDU-750IH(F)			100	30	48		
PDU-750IL(F)		7.5 (10HP)	150	15	96	6309ZZ	6305ZZ
PDU-11KI(H/F)			100	35	60		
PDU-11KIL(F)			150	20	102		
PDU-15KI(H/F)		15 (20HP)	100	40	72	6310ZZ	6306ZZ
PDU-15KIL(F)			150	25	120		
PDU-371TH(F)			3.7 (5HP)	50	30		
PDU-371TM(F)	80	20		30			
PDU-371TL(F)	100	10		60			
PDU-550TH(F)	5.5 (7.5HP)	80	25	36	6308ZZ		
PDU-550TL(F)		100	15	60			
PDU-750TH(F)		100	30	48			
PDU-750TL(F)	7.5 (10HP)	150	15	96	6309ZZ	6305ZZ	
PDU-11KTH(F)		100	35	60			
PDU-11KTL(F)		150	20	102			
PDU-15KTH(F)	15 (20HP)	100	40	72	6310ZZ	6306ZZ	
PDU-15KTL(F)		150	25	120			

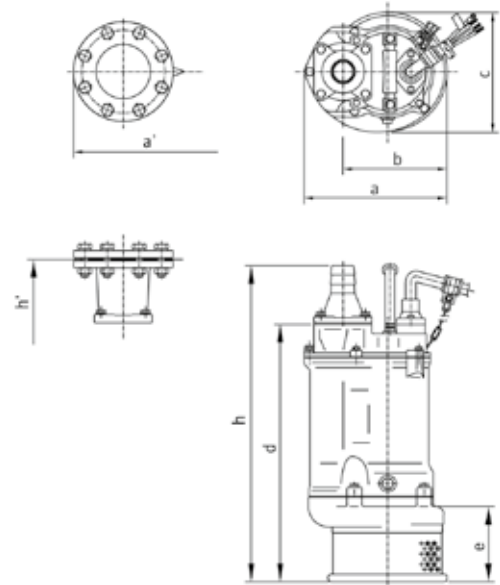

Model	a	a'	b	c	d	e	h	h'
PDU-371IH/TH/VH(F)	301	301	219	253	543	160	667	667
PDU-371IM/TM/VM(F)		669						
PDU-371IL/TL/VL(F)		324						680
PDU-550IH/TH/VH(F)	310	317	224	261	549	160	672	674
PDU-550IL/TL/VL(F)		330						686
PDU-750IH/TH/VH(F)	339	358	253	315	612	190	749	748
PDU-750IL/TL/VL(F)		393						784
PDU-11KI(H/F)	369	398	293	346	653	190	791	790
PDU-11KIL/TL/VL(F)		433						826
PDU-15KI(H/F)	369	398	293	346	703	190	841	840
PDU-15KIL/TL/VL(F)		433						876

PDS Series

5.5~75kW-Heavy Duty

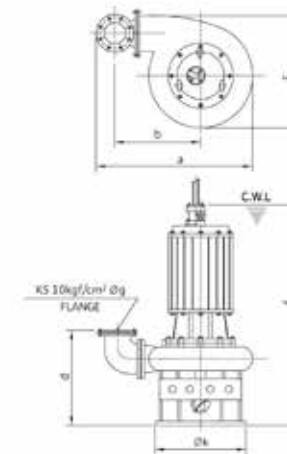

PDS Series

Application

→ Extracting sand and gravels for construction and general industry.

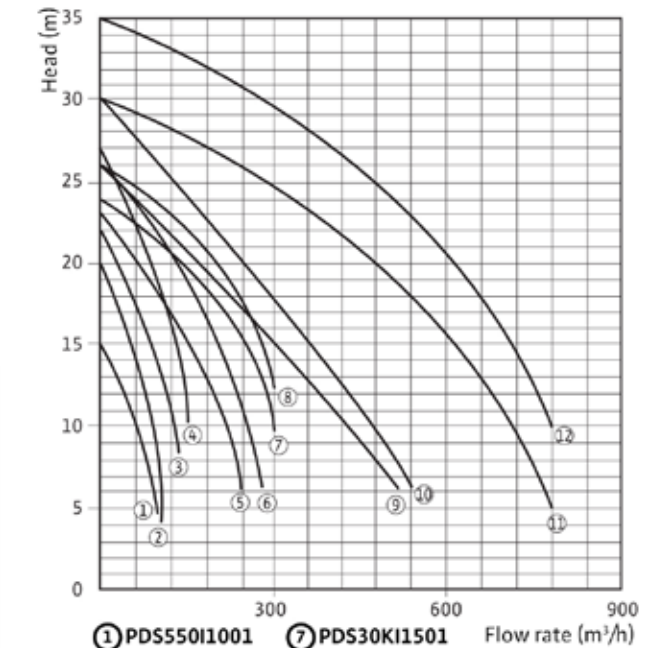

- ① PDS550I1001
- ② PDS750I1001
- ③ PDS11KI1001
- ④ PDS15KI1001
- ⑤ PDS22KI1001
- ⑥ PDS22KI1501
- ⑦ PDS30KI1501
- ⑧ PDS37KI1502
- ⑨ PDS45KI1502
- ⑩ PDS55KI1502
- ⑪ PDS75KI2002
- ⑫ PDS75KI2502

Model	a	b	c	d	øk	f	øg	
PDS550I1001	495	250	365	468	300	645	100	
PDS750I1001								
PDS11KI1001	685	390	385	410	370	980		
PDS15KI1001	658	260		415				955
PDS22KI1001	920	400	650	500	500	1200		
PDS22KI1501								
PDS30KI1501	1100	420	700	575	550	1400		150
PDS37KI1502								
PDS45KI1502								
PDS55KI1502								
PDS75KI2002								
PDS75KI2502	1300	350	800	600	1600	200		
						250		

Model	Power Source	Output (kW)	Discharge (mm)	Head (m)	Flowrate (m³/h)	Speed (rpm)
PDS550I1001	3 Phase 380V 60hz	55	Ø100	10	60	1750
PDS750I1001		75		12	72	
PDS11KI1001		11		15	90	
PDS15KI1001		15		20	90	
PDS22KI1001		22		15	150	
PDS22KI1501		22		15	192	
PDS30KI1501		30	18	192		
PDS37KI1502		37	20	192		
PDS45KI1502		45	15	300		
PDS55KI1502		55	15	360		
PDS75KI2002		75	Ø200	20	480	1150
PDS75KI2502		75	Ø250	25	480	

PDH Series

22~75kW-High Head Type

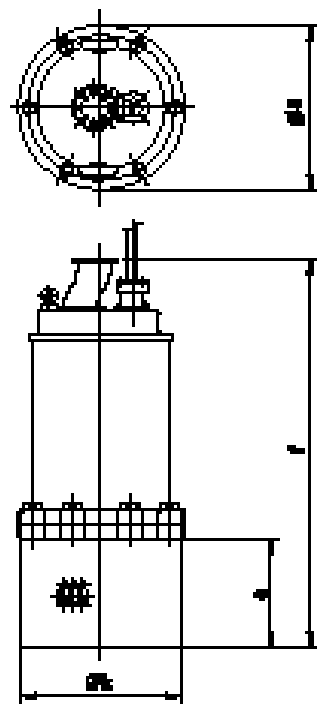

PDS Series

Application

- Drainage for long distance.
- Drainage for mining as well as dam.
- Drainage for civil engineering and construction sites.

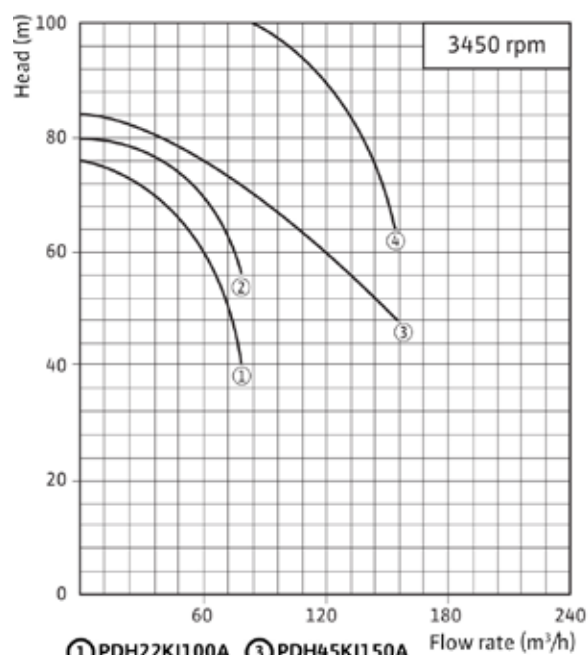

- ① PDH22KI100A ③ PDH45KI150A
- ② PDH30KI100A ④ PDH75KI150A

Model	Øa	e	f	Øk
PDH22KI100A	486	305	1208	467
PDH30KI100A				
PDH45KI150A	620	310	1308	551
PDH75KI150A				

Model	Power Source	Output (kW)	Discharge (mm)	Head (m)	Flowrate (m³/h)	Speed (rpm)
PDH22KI100A	3 phase 380V 60Hz	22	Ø100	60	60	3450
PDH30KI100A		30		70	60	
PDH45KI150A		45	Ø150	60	150	
PDH75KI150A		75		105	120	

Auto Coupling Device (Ø50mm)

Auto Guide Rail System

AD-50

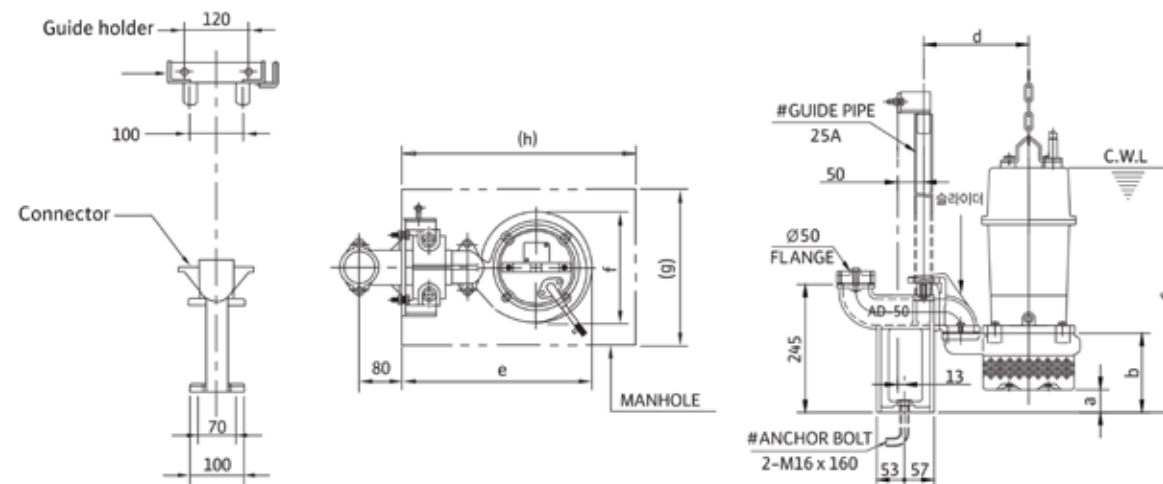

Model	a	b	c	d	e	f	(g)	(h)
PD-401(L401)	56	154	342(336)	186	334	171	290	420
PD-751(L901)	56	154	357(360)	186	334	171	290	420
PDV-400(L400)	59	154	362(359)	186	331	169	290	420
PDV-750(L900)	59	154	377(384)	186	331	169	290	420
PDV-752(952)	59	154	354(357)	186	331	169	290	420
PDN-1400(1405)	15	154	354	186	340	195	290	430
PD-1505(1515)	44	152	469(405)	201	347	193	290	420

*AD-50 is not available for PD-1500M/MA

Auto Coupling Device (Ø50mm)

Auto Guide Rail System

AD-/65/80/100/150

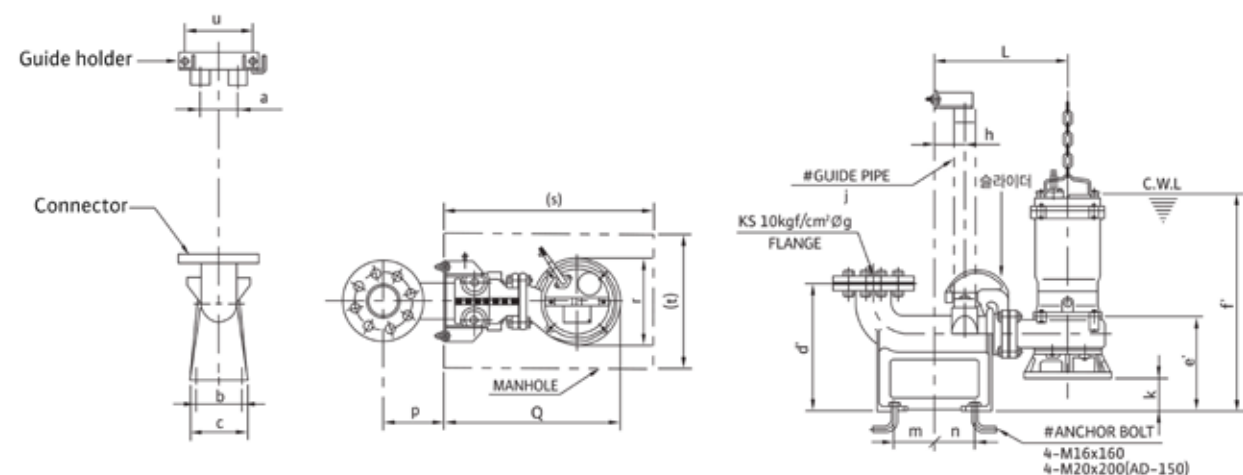

Model	Auto coupling	a	b	c	d'	e'	f'	Øg	h	j	k	L	m	n	p	Q	r	(s)	(t)	u
PD-2200 Series	AD-65	80	120	150	220	183	493	65	50	32	64	307	95	65	145	413	212	510	350	120
2205 Series	AD-80	100	120	150	330	223	533	80	80	50	104	350	105	105	160	451	212	550	350	180
PD-3701 Series	AD-65	80	120	150	220	203	543	65	50	32	25	374	95	65	145	506	262	560	450	120
3705 Series	AD-80	100	120	150	330	242	577	80	80	50	64	417	105	105	160	548	262	600	450	180
PD-5500 Series	AD-80	100	120	150	330	246	615	80	80	50	65	422	105	105	160	548	262	600	450	180
PD-7500 Series	AD-100	100	200	238	330	299	660	100	80	50	43	446	114	115	160	592	314	670	500	180
PD-11K Series		100	200	238	330	299	700	100	80	50	42	441	114	115	160	610	330	700	570	180
PD-15K Series		100	200	238	330	299	750	100	80	50	42	441	114	115	160	610	330	700	570	180
PDN-2200 Series	AD-65	80	120	150	220	207	517	65	50	32	47	307	95	65	145	421	228	510	350	120
PDN-2205 Series																				
PDC-2201 Series	AD-80	100	120	150	330	246	556	80	80	50	86	350	105	105	160	464	228	550	350	180
PDN-2500 Series																				
PDN-2505 Series																				
PDC-2500 Series																				
PDC-2505 Series																				
PDV-3700 Series	AD-65	80	120	150	220	217	544	65	50	32	30	375	95	65	145	541	332	630	500	120
PDC-3700 Series	AD-80	100	120	150	330	256	584	80	80	50	70	418	105	105	160	584	332	670	500	180
PDN-5500 Series	AD-80	100	120	150	330	258	723	80	80	50	69	468	105	105	160	661	388	710	570	180
PDN-7500 Series	AD-100	100	200	238	330	258	723	100	80	50	69	468	114	115	160	661	388	710	570	180
PDN-15K Series	AD-150	100	235	290	400	339	892	150	80	50	62	588	97	113	190	811	448	900	700	180

Auto Coupling Device (Ø50mm)

Auto Guide Rail System

AD-50

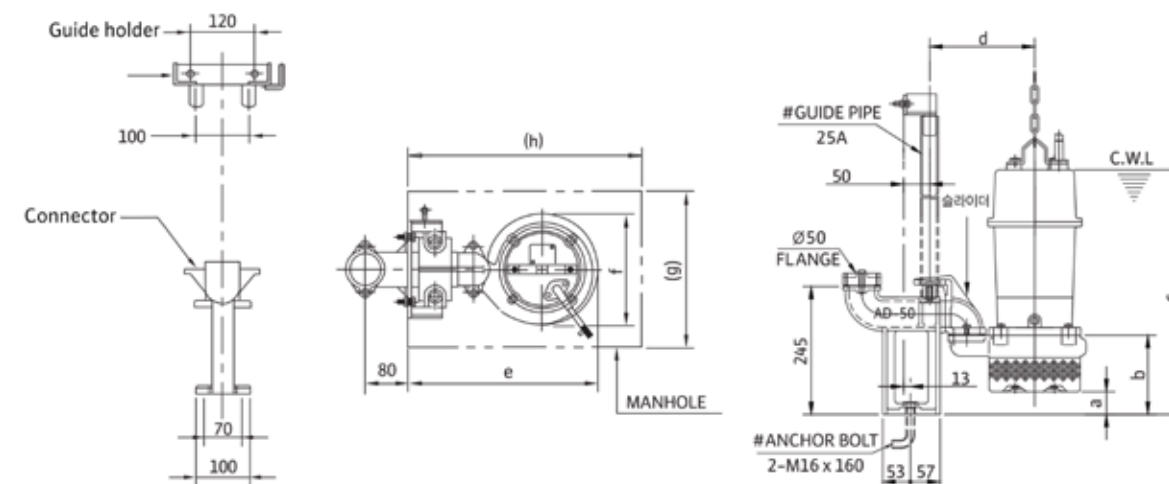

Model	a	b	c	d	e	f	(g)	(h)
PD-401(L401)	56	154	342(336)	186	334	171	290	420
PD-751(L901)	56	154	357(360)	186	334	171	290	420
PDV-400(L400)	59	154	362(359)	186	331	169	290	420
PDV-750(L900)	59	154	377(384)	186	331	169	290	420
PDV-752(952)	59	154	354(357)	186	331	169	290	420
PDN-1400(1405)	15	154	354	186	340	195	290	430
PD-1505(1515)	44	152	469(405)	201	347	193	290	420

**AD-50 is not available for PD-1500M/MA*

Which aspects are to be observed during application in the building services?

Both the sewage generated in a building or on a piece of land and the rainwater which accumulates on courtyard and roof surfaces should be pumped to the sewer system with the aid of pumping stations and lifting units, insofar as they do not flow naturally downhill into the local sewage network. There are different ways to dispose of this sewage, depending on the respective fluids to be pumped. Wilo submersible pumps and sewage lifting units are designed especially to meet these different requirements and comply with currently valid EN standards. Dimensioning must be carried out in accordance with DIN EN 12050/12056 – Drainage stations for buildings and sites. A distinction is made here between sewage emerging from discharge points above the local backflow level, which must be guided to the public sewer system by taking advantage of natural declines, and sewage from discharge points whose water levels in the anti-siphon trap lie below the local backflow level. The backflow level is defined in bylaws. The upper street edge is usually taken as a rough guide value. Sewage (rainwater and wastewater) that accumulates below the backflow level must be conveyed to the public sewer system via automatically operating lifting units – Wilo sewage lifting units or Wilo submersible pumps.

The following details, among others, are to be observed for system dimensioning and design in accordance with DIN 1986-100, EN 12050 and EN 12056:

- Lifting units are to be designed in terms of performance in such a way that a minimum flow velocity of ≥ 0.7 m/s is guaranteed for the prescribed nominal diameters of the pressure pipe.
Prescribed minimum nominal diameters:
Sewage lifting unit for sewage containing faeces without comminution unit: DN 80
Sewage lifting unit for sewage containing faeces with comminution unit: DN 32
Sewage lifting unit for sewage free of faeces: DN 32
Sewage lifting unit for limited use for sewage containing faeces without comminution unit: DN 25
Sewage lifting unit for limited use for sewage containing faeces without comminution unit: DN 20
- The pressure pipe of a lifting unit must be equipped with a non-return valve and installed with its invert above the backflow level (backflow loop). The pressure pipe may not be connected to wastewater downpipes.
- Wastewater gate valves (supply and pressure sides) are to be installed in accordance with DIN 1986-100, EN 12050/EN 12056.
- Ventilation lines for lifting units are to be guided to heights above the roof level; the minimum nominal pipe diameter is DN 70 for sewage lifting units.

- Inlet pipes are to be installed with sufficient slope (a minimum of 1:50).
- It is practical to install pipes flexibly through masonry.
- An automatic standby pump is to be provided if the sewage drain pipe does not allow for interruptions.
- Switchboxes and signalling systems are to be installed at a dry, easily accessible position. The signalling system is to be mounted at an observable position.
- Lifting units must be serviced regularly. At least:
1x per year in single-family homes
Every six months in apartment buildings
Every three months for systems in commercial buildings
- The installation area is to be provided with sufficient ventilation and lighting. A working space of at least 600 mm is to be provided above and next to all operating elements and all parts requiring maintenance. The lifting unit must be provided with anti-buoyant mounting.
- Sewage containing mineral oils or explosive admixtures must be guided through oil precipitators and/or petrol precipitators; those containing fatty substances must go through grease traps and those with sand through grit chambers. Acidic sewage must be neutralised. Pumps are generally to be made with Ex-protection.

What installation types are there in sewage technology?

Very different types of installations are used in submersible motor systems in municipal applications. The type of installation depends mainly on the application purpose and the investment volume.

Basically, there are three different main installation types:

- Wet well installation, stationary
- Wet well installation, portable
- Dry well installation, stationary

The pipe chamber installations are also required. The type of installation depends mainly on the requirements of the consultant and the operator. Different viewpoints have arisen, which are each justified in terms of the individual field of application.

Wet well installation or stationary tank installation

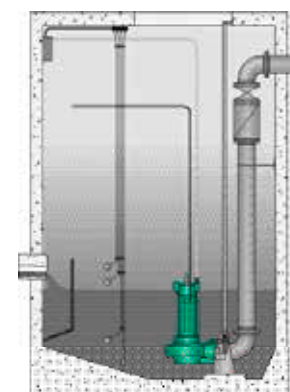

With wet well installation, the pump is installed in the fluid to be pumped. The motor is cooled by the circulating sewage. The advantage of this type of installation is low investment costs compared to the more sophisticated pumping station designs for dry-installed sewage pumps. In such a case, a construction above ground or an intermediate base in the pump chamber for the pumps is not required. In greater depths, an intermediate ceiling is necessary.

The pump is fastened by means of a suspension unit with lowering mechanism. That allows the pump to be "pulled" at all times, e.g. for maintenance work.

The coupling base and the elbow are usually cast in one piece. The guide consists of two pipes, thus preventing any twisting. The Wilo coupling connection is made in such a way that a lip prevents the seal ring from falling out.

The pressure pipe made of a galvanised steel pipe, or ideally of a stainless steel pipe, is fitted directly on the suspension unit via flanges and leads out of the pump chamber. The pump chamber can be made at low costs from ready-made concrete pump chambers equipped with elastomer seals in accordance with EN 1917 (national addition: DIN 4034 T1). However, one-piece PEHD pump chambers without joints are a better solution, since these prevent any infiltration of external water.

As shown on the diagram alongside, this installation type gives the operator the option of special pump chamber geometries adjusted to individual requirements, the use of additional flushing valves or the installation of vortex impellers with special mixer head technology.

The disadvantage of a wet well installation is the lack of ease of maintenance. In addition, with a wet-installed submersible sewage pump, the water level can only be lowered to a certain level, since optimum cooling of the motor is only possible in submerged condition.

Stationary dry well installation

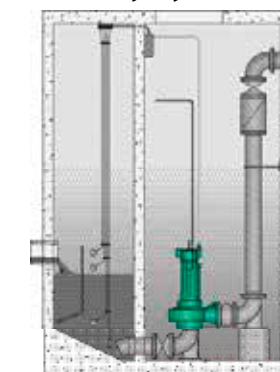

The dry well installation variant, in particular the dry-installed submersible pump, provides a number of advantages compared to dry-installed pumps, and also compared to wet-installed submersible pumps.

Installation principle of a dry-installed submersible pump

The main difference from a wet-installed submersible pump is the design of the motor. It is a fully encapsulated motor with internal closed-circuit cooling. A distinction is made between an open cooling system and a closed cooling system. With an open cooling system, the fluid to be pumped is used as the coolant. With a closed system (single-chamber or two-chamber system), cooling is performed by an external fluid, such as water-glycol or medical white oil, in a closed circuit.

Another main difference from the wet-installed submersible pump is that the dry-installed submersible pump is not installed in the fluid to be pumped. In terms of the technical construction, an intermediate base is required directly in the pumping station. The major advantages are the combination. On the one hand, this submersible pump offers all the benefits of a dry-installed pump and, on the other hand, all the benefits of a submersible pump, such as being overflow-proof.

As already mentioned, the pump is installed in a separate pump room. The pump is fastened to the inlet pipe unspectacularly via a pipe elbow.

Advantages compared to dry-installed pumps (no submersible pumps)

- Overflow-proof and thus more operational reliability
- Low-maintenance carbide mechanical seals or seal cartridges
- No couplings or V-belts, thus fewer wearing parts and less maintenance required
- Explosion protection possible at all times
- Clean and hygienic working conditions
- Easy maintenance

Portable installation

With this type of installation, the motor is cooled in the same way as for stationary wet well installation. However, the pump is not fastened firmly in the pump sump by means of a suspension unit. The pump can thus be installed in any pump chamber via a base component on the pump housing. With the right couplings, hoses of appropriate length can be installed on the pressure port. When selecting the pump, hydraulic conditions, such as volume flow and delivery head as well as the pump's NPSH, must also be taken into account.

Portable pumps are frequently used as emergency drainage or residual drainage pumps for municipal applications.

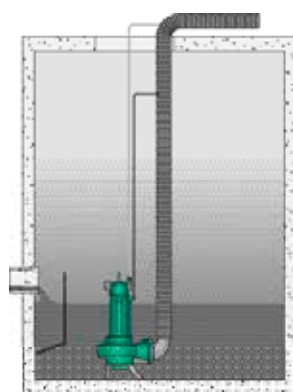
**What impeller shapes and properties are there?**

To ensure the fluid can be pumped reliably, the correct impeller must be used for the corresponding fluid. Each impeller shape has its advantages and disadvantages here. The following impeller shapes are currently used in our hydraulics:

- Single-vane impeller (single-channel impeller)
- Multi-vane impeller with 2, 3 or 4 channels (multi-channel impeller)
- Vortex impeller
- SOLID impeller
- Propeller impeller (axial impeller)

Single-channel and multi-channel impellers and the SOLID impellers are available in a closed and half open design. It should be noted here that the efficiency of the half open design is generally lower than that of the closed design.

In addition to the shape of the impeller the level of process reliability is also dependent on the nominal diameter of the hydraulics. Vortex impellers tend to be used for small nominal diameters (DN 50...150). Multi-channel impellers, on the other hand, tend to be used for large nominal diameters (DN 200...600).

Furthermore, there are hydraulics which are also equipped with a cutting device or a mechanical stirring apparatus. The additional cutting device breaks up the admixtures in the fluid, thereby facilitating the pumping process. The cutting device is installed internally or externally depending on the hydraulics selected, and it is combined with a half open single-channel impeller or a half open multi-channel impeller.

When using the additional mechanical stirring apparatus, the suction area is continuously stirred up. This prevents settlement of the solid material and the resulting encrustation. Due to the narrowly limited flow zone of the mixer head only the suction area of the pump is affected. The mechanical stirring apparatus is mostly used in combination with a vortex impeller.

When using the hydraulics, the following points must be observed:

- The fluid can exhibit a max. dry matter content (DM) of 8 %.
- The fluid must flow independently of the hydraulics.
- The friction losses in the discharge pipeline and the specific weight of the fluid must be taken into account in the calculations.
- The motor power is to be designed with an adequate reserve for the current operating conditions.

Vortex impeller

Recommended nominal diameters: DN 50 to DN 150

Properties:

- Very low-clogging, as it is insensitive to fluids containing fibres and textiles
- Very smooth operation
- High wear resistance
- Lower efficiency
- Suitable for pumping gaseous fluids
- Sludge pumping

Fields of application:

- Untreated sewage
- Activated sludge
- Raw and digested sludge
- Mixed water
- Fluids with problematic constituents and wearing constituents

Single-vane impeller (single-channel impeller)

Design: closed and half open

Recommended nominal diameters: DN 50 to DN 250

Properties:

- Low-clogging
- Smooth operation
- Wear-resistant
- Steep pump curve
- Good efficiency
- Sludge pumping

Fields of application:

- Untreated sewage
- Circulation and heating sludge
- Mixed water
- Raw and digested sludge
- Activated sludge

Double-vane impeller (multi-channel impeller)

Design: closed

Recommended nominal diameters: DN 150 to DN 400

Properties:

- Low-clogging (depending on nominal diameter and fluid)
- Very smooth operation
- Wear-resistant
- Steep pump curve
- Good efficiency
- Sludge pumping

Fields of application:

- Rake-cleaned sewage
- Mechanically treated sewage
- Industrial wastewater
- Landfill water
- Activated sludge
- Industrial sewage

Three and four-vane impeller (multi-channel impeller)

Design: closed

Recommended nominal diameters: DN 200 to DN 600

Properties:

- Low-clogging (depending on nominal diameter and fluid)
- Very smooth operation
- Steep pump curve
- Very good efficiency

Fields of application:

- Rake-cleaned sewage
- Mechanically treated sewage
- Industrial wastewater
- Landfill water
- Activated sludge
- Industrial sewage

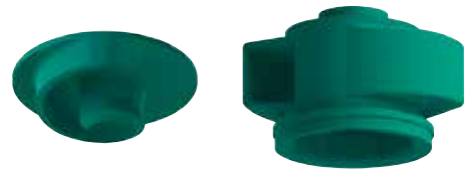
SOLID impeller

Design: closed and half open

Recommended nominal diameters:

- Closed design: DN 150 to DN 400
- Half open design: DN 80 to DN 150

Properties:

- Closed design
 - Very low-clogging (depending on nominal diameter and flow rate)
 - Very smooth operation
 - Wear-resistant
 - Good efficiency
 - Pumping of gaseous fluids
 - Sludge pumping
- Half open design
 - Hardly any clogging
 - Lower efficiency than the closed design
 - Pumping of gaseous fluids
 - Sludge pumping

Fields of application:

- Untreated sewage
- Industrial wastewater
- Landfill water
- Activated sludge
- Industrial sewage

Propeller impeller (axial impeller)

Possible pipe diameters: 340 mm, 500 mm and 760 mm

Properties:

- Very smooth operation
- Very steep pump curve
- Very good efficiency

Fields of application:

- Fluids with small amounts of dirt
- Rainwater
- Return activated sludge
- Circulation of activated sludge
- Water drawing units, etc.

THE FUTURE IS CONNECTED.

Authorized Distributor:

www.trimcorph.com

TRIMCOR TRIUMPH MACHINERY CORPORATION
THE PUMP, MOTOR & DRIVES SPECIALIST



