

LITTLE CHAMP



Task master for light industrial and domestic applications

DC Little Champ Pump

Roto's Little Champ pump range has been developed for general purpose pumping applications that demand high performance and durability. These multi taskers can be used for dosing, transfer and injection duties for a wide variety of fluids. These pumps are available in 4 sizes with flow rates, ranging from 780 L/Hour – 7980 L/Hour and pressures upto 2.8 bar.

Distinctive Design Features and Benefits

- Flow is directly proportional to the speed
- Excellent suction lift capabilities
- Low shear and linear flow
- Can handle liquid with varying viscosity
- Can handle liquid with fine solids
- Minimum impact on efficiencies with varying heads

Typical applications

- Transfer and dosing of chemicals and alkalies
- Transfer duties in food processing, winery and vegetable oils
- Drainage of septic tanks
- Feeding to oily water separators
- Drawing water from wells, creeks or shallow bores
- Hosing down of cattle and stock sheds
- Automatic water pressure systems
- Brine injection
- Feeding ponds and sprinkler systems
- Diesel transfer
- Handling surfactants and detergents

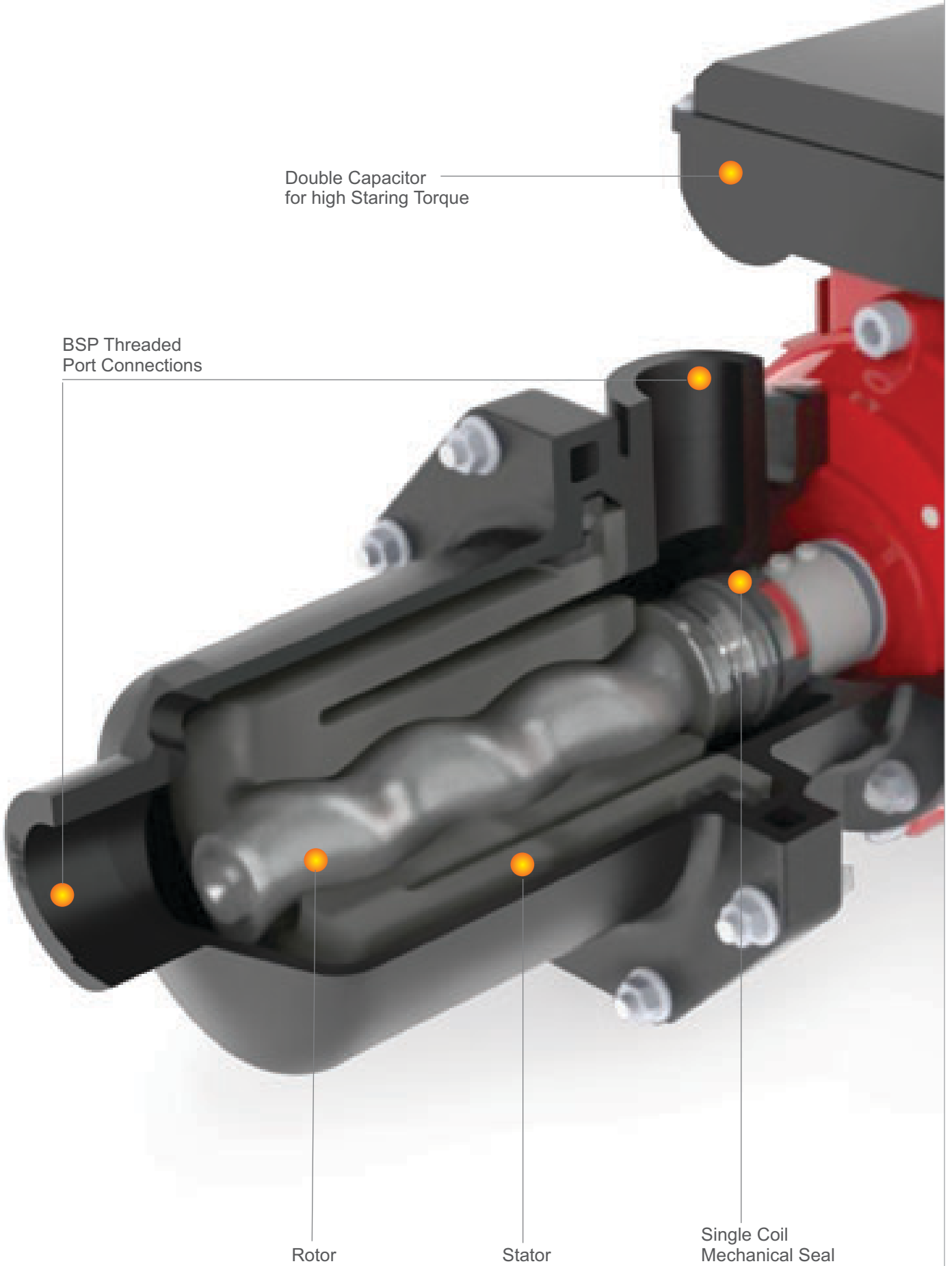

Double Capacitor
for high Starting Torque

BSP Threaded
Port Connections

Rotor

Stator

Single Coil
Mechanical Seal



Standard IEC
Frame Motor

Material options

- UV resistant acetal co-polymer housing for pump sizes DC 11 & DC 31
- C.I. Housing parts for pump sizes DC 41 & DC 51
- Stainless steel hard chrome plated rotor
- Stainless steel hardware
- Stator option
 - ◆ Natural
 - ◆ Nitrile (Standard)
 - ◆ High Nitrile
 - ◆ Fluoroelastomer (DC11 and DC 31 only)

PERFORMANCE CURVES

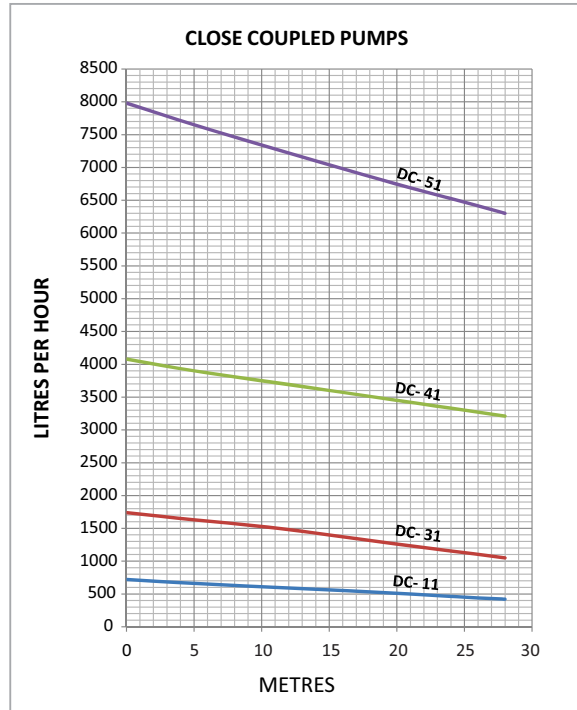
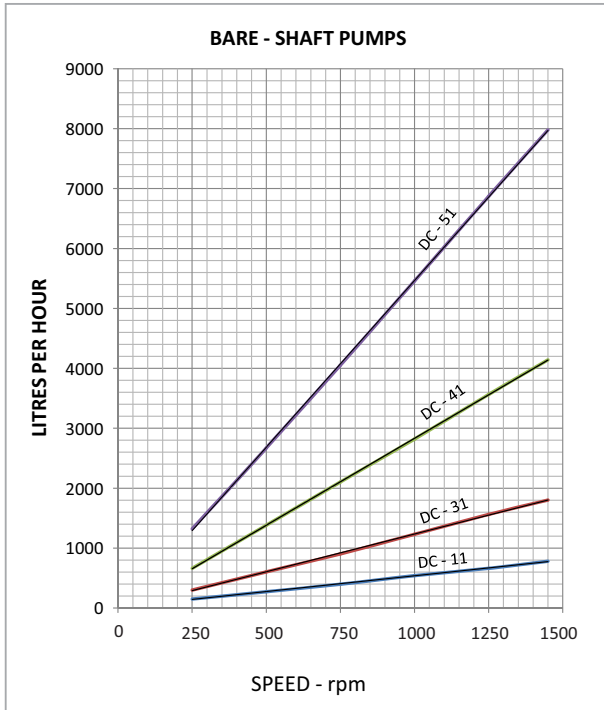

Dimensional details

DCAAC-011/031

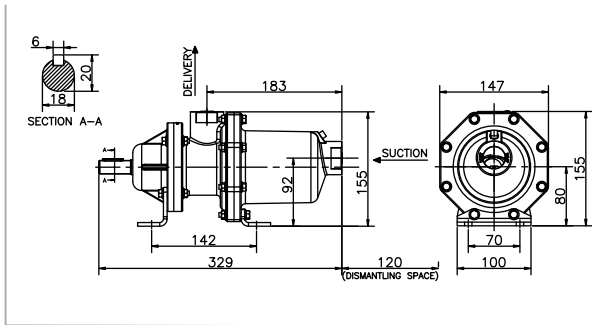

DCCC-011/031

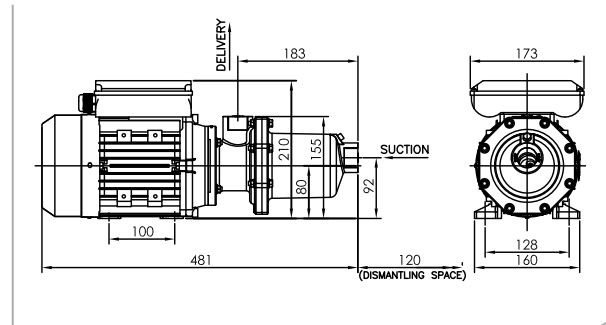

DCAA-041/051

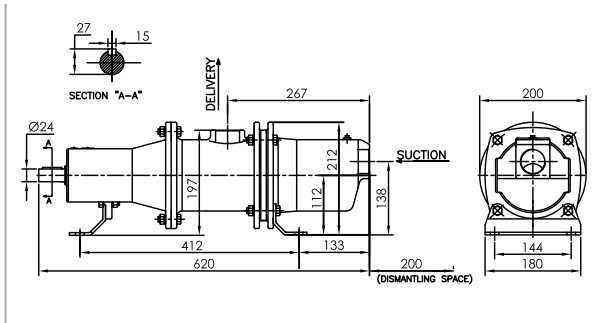

DCCA-041/051

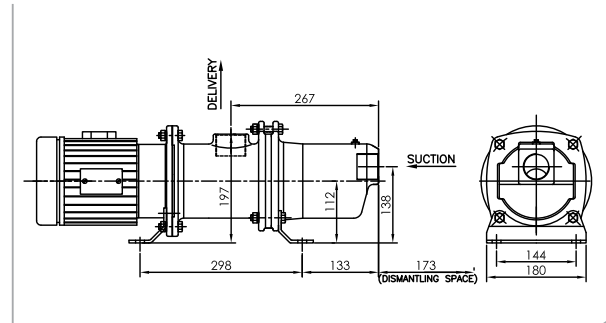

ALL DIMENSIONS ARE IN MM

Pump Type	Port Size	Pump Weight Kgs (approx.)		Motor Rating (KW)	Max. Suction Lift
		Bare Shaft	Closed Coupled		
DC-11	1" BSP	2.6	10.3	0.37	7.5 Meter
DC-31	1" BSP	3.0	10.7	0.37	6.5 Meter
DC-41	1.5" BSP	28.1	31.0	0.75	5.5 Meter
DC-51	1.5" BSP	28.5	31.5	1.1	4.5 Meter

*Overrated motors

Roto Pumps Limited, Manufacturing Plant, India



Corporate Office & Export Warehouse, India

Manchester Office & Warehouse

Melbourne Office & Warehouse



Authorized Distributor:

www.trimcorph.com

TRIMCOR TRIUMPH MACHINERY CORPORATION
THE PUMP, MOTOR & DRIVES SPECIALIST