

QTS SERIES

TWIN SCREW PUMPS FOR INFINITE APPLICATIONS

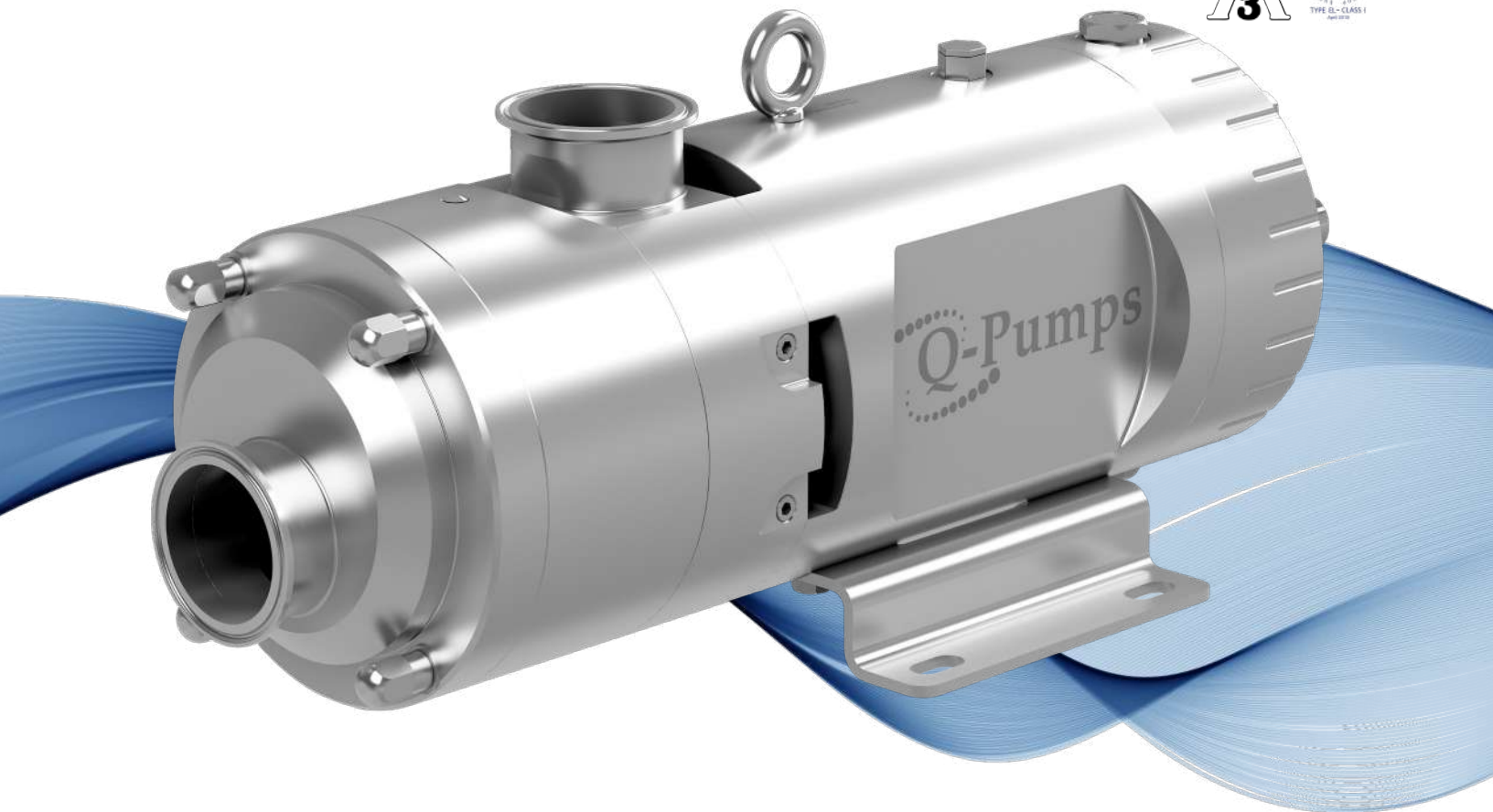

QTS SERIES

The QTS is a twin screw pump, 100% sanitary and ideal as a process pump and CIP, which reduces costs and maintenance times. Available with rectangular inlet. Ideal for products with high air or gas content. Certifications: 3-A, FDA and EHEDG



Φ 850 GPM / 3,218 LPM

μ up to 1,000,000 cP

P 362 psi / 25 bar
693 ft / 211 m

T 120°C / 248°F

CHARACTERISTICS

- Manufactured 100% in stainless steel, wet parts in SS 316L
- Constant flow, free of pulsations
- 100% CIP* at high speeds
- There is no contact between rotor / rotor / housing when working at high pressures
- Speed of up to 3,500 rpm (depends on the viscosity of the product)
- Ideal as a process and CIP pump* with the same equipment reducing costs
- Perfect for handling constant flows and product measurements
- Large suction capacity that eliminates low NPSH problems
- Handling of products with low and high viscosities (from 1 to 1,000,000 cP)
- Ideal for abrasive products
- 100% drainable
- Bidirectional: It is possible to recover the product from the line due to being reversible
- Self-priming (high degree of suction)
- Narrow tolerances for vacuum capacity
- Certified by EHEDG (n° UT 033018) and 3-A (n° 1805)
- Options available in other materials such as Hastelloy C-276 **



* Only available for mechanical seals

** In all the parts in contact with the product

INNOVATING POSITIVE DISPLACEMENT

DIFFERENT SIZES:



* Intermediate capacity between QTS 300 and QTS 400, which allows the user to select the pump that best suits their processes.

* Ideal for dosing, supply and packaging of products with low flow rates, regardless of viscosity.

AVAILABLE SEALS:

Mechanical Seal



- Long useful life
- Cleaner (EHEDG)
- Can work in vacuum up to -12 psi / 0.83 bar
- High pressure and speed management
- Ideal for abrasive products
- Single or double

O-Ring Seal



- Economic option
- It can be replaced quickly
- Easy maintenance
- Ideal for soft products (glycerin, creams, fats, etc.)
- EPDM and Viton

Lip Seal



- Handles abrasive products
- Does not require lubrication

ADVANTAGES VS. OTHER PUMPS

QTS SERIES

Other technologies

Integrity of suspended solids

- | | |
|---|---|
| <ul style="list-style-type: none"> • Handles suspended solids up to 38 mm / 1.5 "without mistreating them. • Continuous flow and delicate handling of fluids • High and low speeds (up to 3,500 rpm) | <ul style="list-style-type: none"> • It is not possible to keep solids intact • Abuse to the product by the impeller's cut • Limited maximum speeds in lobular pumps (up to 600 rpm) |
|---|---|

CIP and NPSH

- | | |
|---|---|
| <ul style="list-style-type: none"> • The QTS pump is 100% CIP • Self-draining and self-priming • Ideal as a process and CIP pump with the same equipment. • Large suction capacity that eliminates problems of low NPSH available. • Air handling in the line of up to 60% | <ul style="list-style-type: none"> • Most existing positive displacement pumps are not 100% CIP. • It is not possible to clean the production line using the same pump. • Difficulty to prime the pump (limited suction capacity). • Requirement of higher NPSH |
|---|---|

Damage, wear and maintenance

- | | |
|---|--|
| <ul style="list-style-type: none"> • Handling of abrasive products since its surface is hardened, protecting it from premature wear. • Less damage to the pump when there is no contact between rotor / rotor / casing, when working at high pressures and avoiding long downtimes. | <ul style="list-style-type: none"> • Premature wear with abrasive products • Damage of seals / stator when operating dry • Long stoppages for maintenance |
|---|--|

Operation and performance

- | | |
|---|--|
| <ul style="list-style-type: none"> • The QTS pump is silent • By being able to handle trapped air, there is less chance of cavitation. • Less slippage of the product inside the pump. • It has no dead zones • High and constant flow | <ul style="list-style-type: none"> • Noise and excessive vibration • Cavitation situations with low and high speeds. • High slip of the product inside the pump. • Dead zones • Minor and pulsating flows |
|---|--|

APPLICATIONS



ADVANTAGES

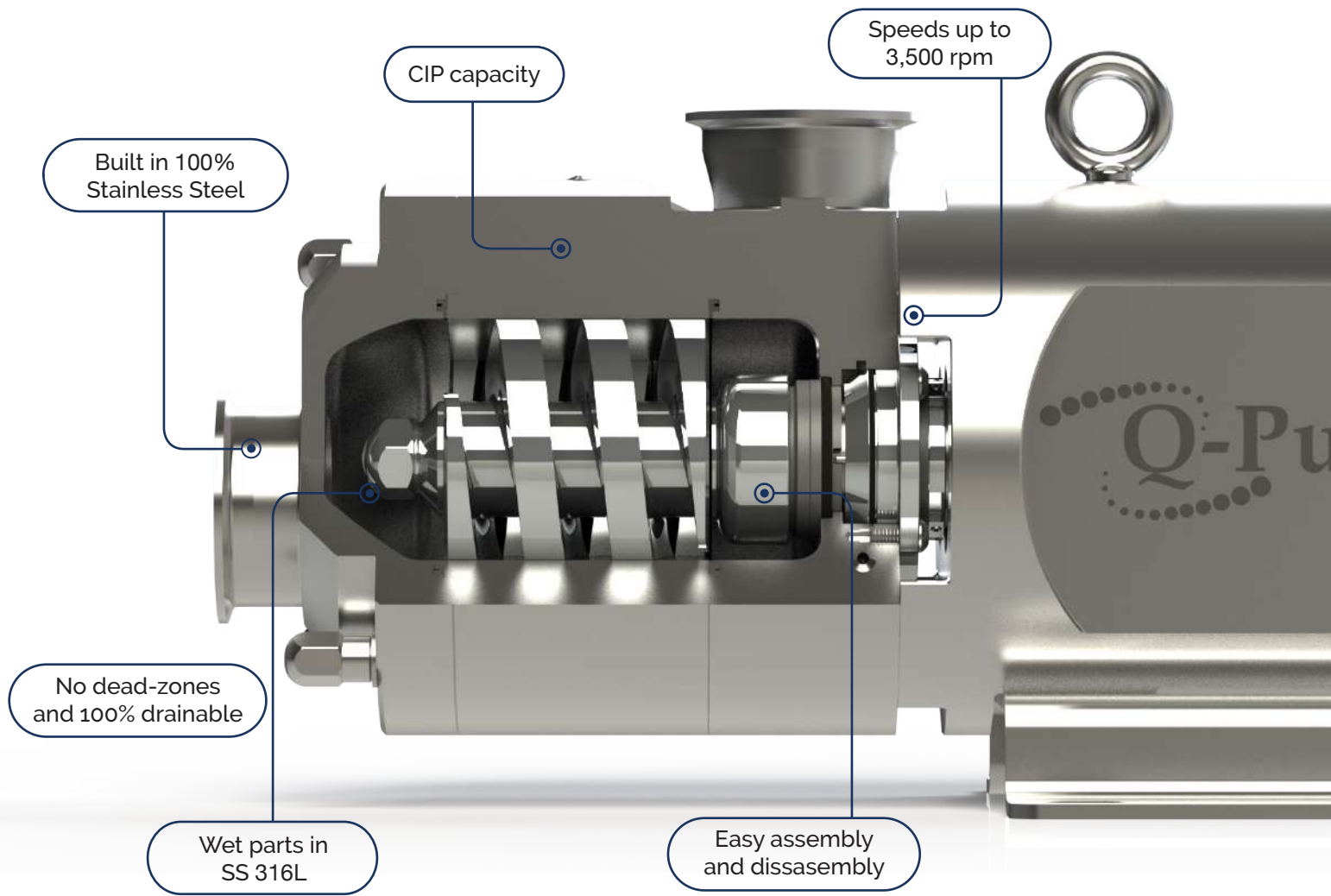

With different screw options for solid handling



RECTANGULAR INLET



QTS-3R4-HM4

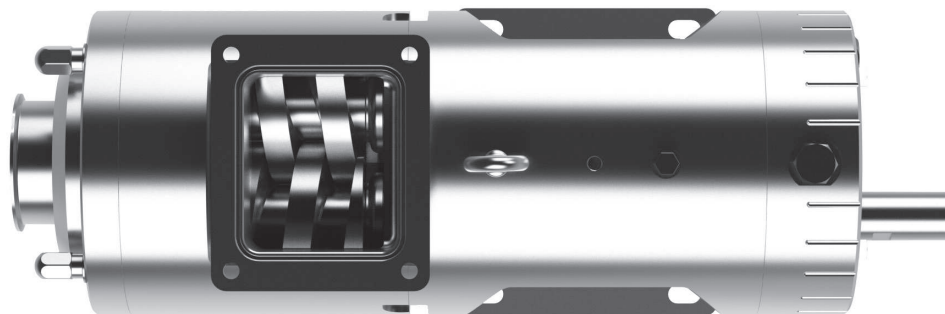

Q-Pumps is the only manufacturer of pumps in twin screw that offers the widest range of different options for rectangular entrances, allowing the user to select the one that best suits their production processes.

- Ideal for pasty products such as meats and doughs
- High viscosity handling (100,000 to 1,000,000 cP)
- Ideal for products with high air or gas content
- Perfect for vacuum applications with high and low viscosity products
- Ideal for applications with low NPSH
- CIP capacity

PUMP DIMENSIONS

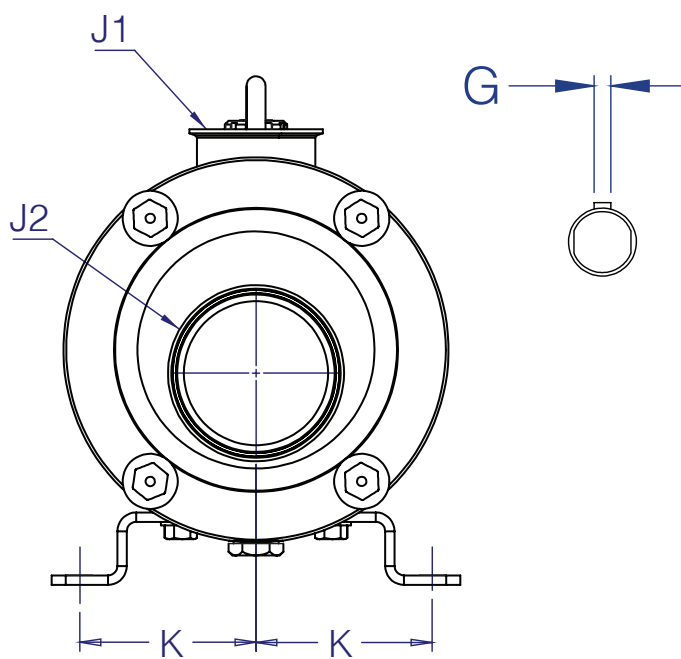
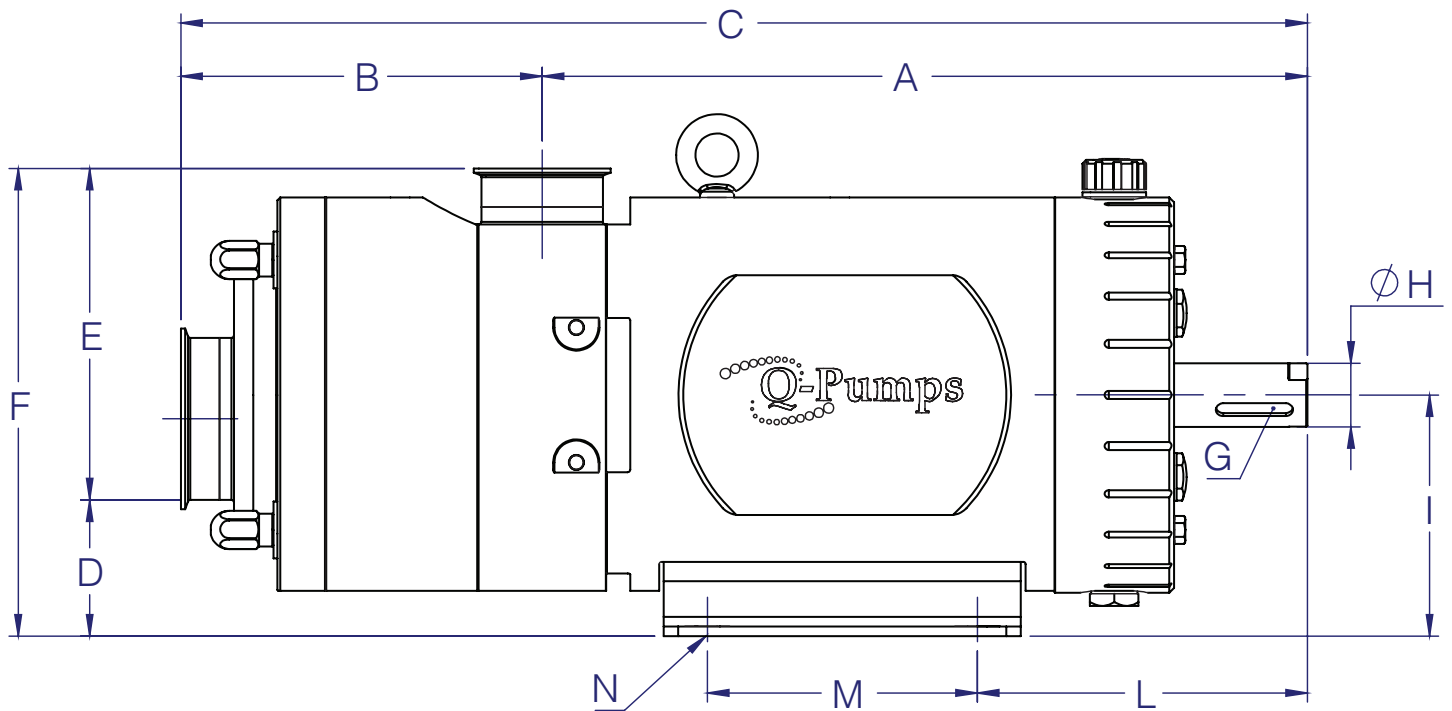

Scan the QR Code for the pump dimensions



QTS SERIES

TWIN SCREW PUMP FOR INFINITE APPLICATIONS

Model	Maximum capacity				Conection Sizes	Differential pressure	Viscosity	Temperature
	gpm		ipm					
	Aplication	CIP	Aplication	CIP				
QTS 25	7-5	15	30	60	1/2",3/4",1"	150 psi/10bar	up to 1,000,000 cP	up to 300°F (120°C)
QTS 100	35	70	132	265	1.5"/2"	260 psi/18bar		
QTS 200	93	185	352	700	2",2.5",3"	up to 360 psi/25 bar		
QTS 300	223	405	844	1533	3",4"			
QTS 350	399	642	1510	2430	3",4",6"			
QTS 400	570	850	2158	3218	4",6"			

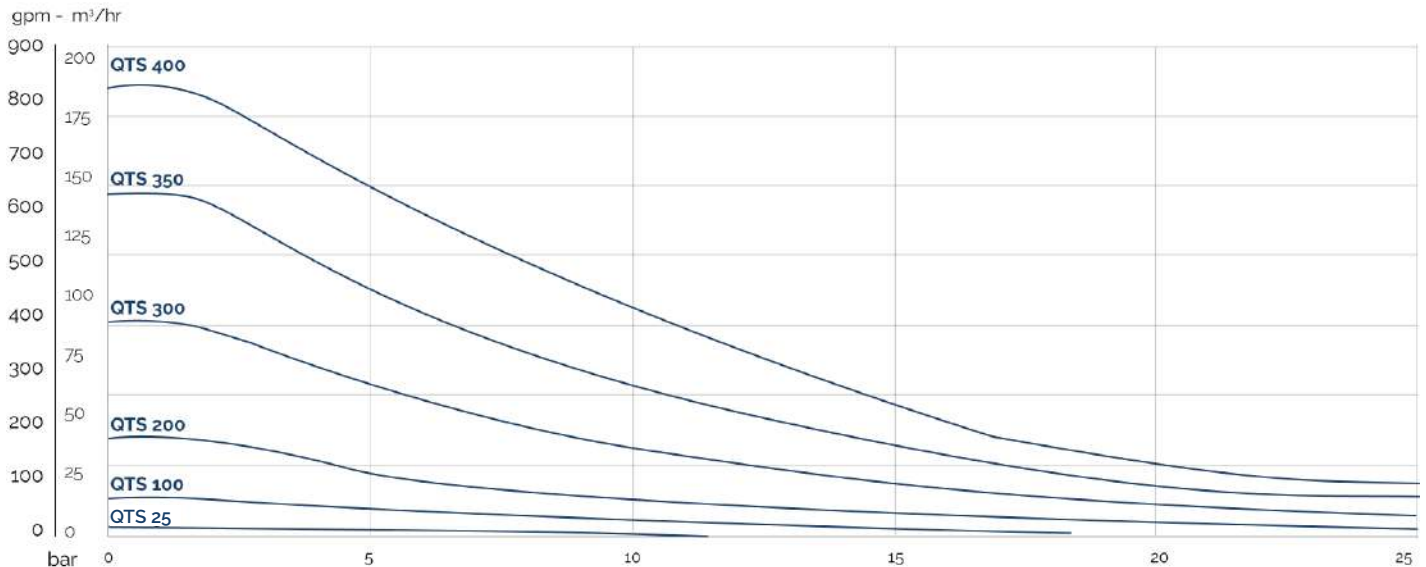

**Curves only for reference

Authorized Distributor:

www.trimcorph.com



TRIUMPH MACHINERY CORPORATION
THE PUMP, MOTOR & DRIVES SPECIALIST