

ROTAN® HD

Heavy Duty Pumps

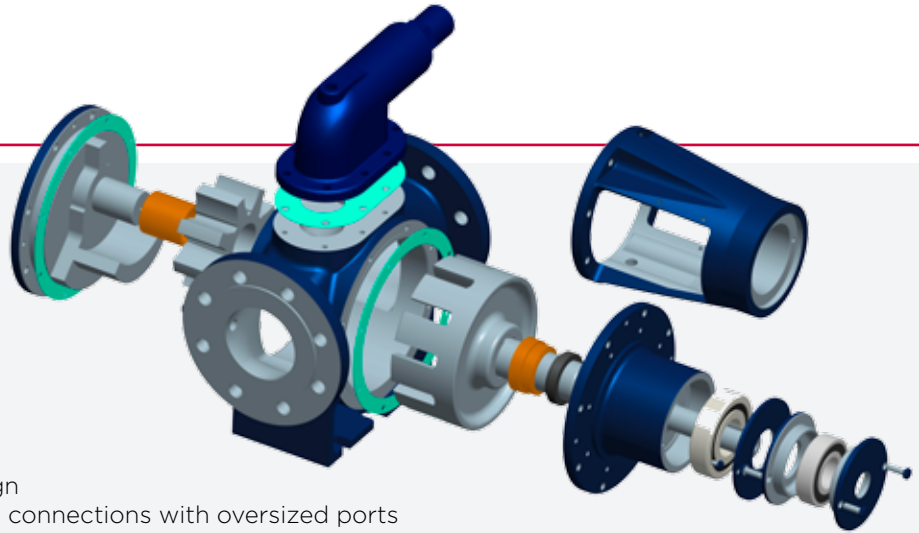

Key features and benefits

- Flexible sealing options
- “True” back pull-out design
- Opposing inlet and outlet connections with oversized ports
- Shaft supported by two ball bearings in single sealed configuration
- Self-priming with large suction capabilities
- Low NPSH requirements
- Self-draining, integral safety relief valve
- No speed reduction required in six smaller sizes
- Complete heating/cooling jacketing available



Pumps in cast iron, for a wide range of viscous, non-corrosive liquids. HD pumps are specifically designed for difficult applications and those involving high viscosity liquids.

HD pumps are known by their sturdy and simple construction. Available with 90° angular configuration.

Production stops are the most costly activity in industry.

That is why companies all over the world rely on high quality pumps like DESMI ROTAN®.

Capacity Range	Up to 250 m ³ /h / 1100 gpm
Speed	Up to 1750 rpm
Differential Pressure	Up to 16 bar / 232 psi
Suction Lift	Up to 0,5 bar / 7.25 psi vacuum while priming Up to 0,8 bar / 11.6 psi vacuum while pumping
Viscosity Range	Up to 250,000 cSt
Temperature	Up to 250°C / 482°F
Pumping of: Oil, Asphalt, Chocolate, Paint/Lacquer, Molasses, Soap, Additives, Polyol, Viscose, Sulphate soap, Maltose, Grease, Pitch, Base oil, Bitumen, Polyester	

Selection of Pump size

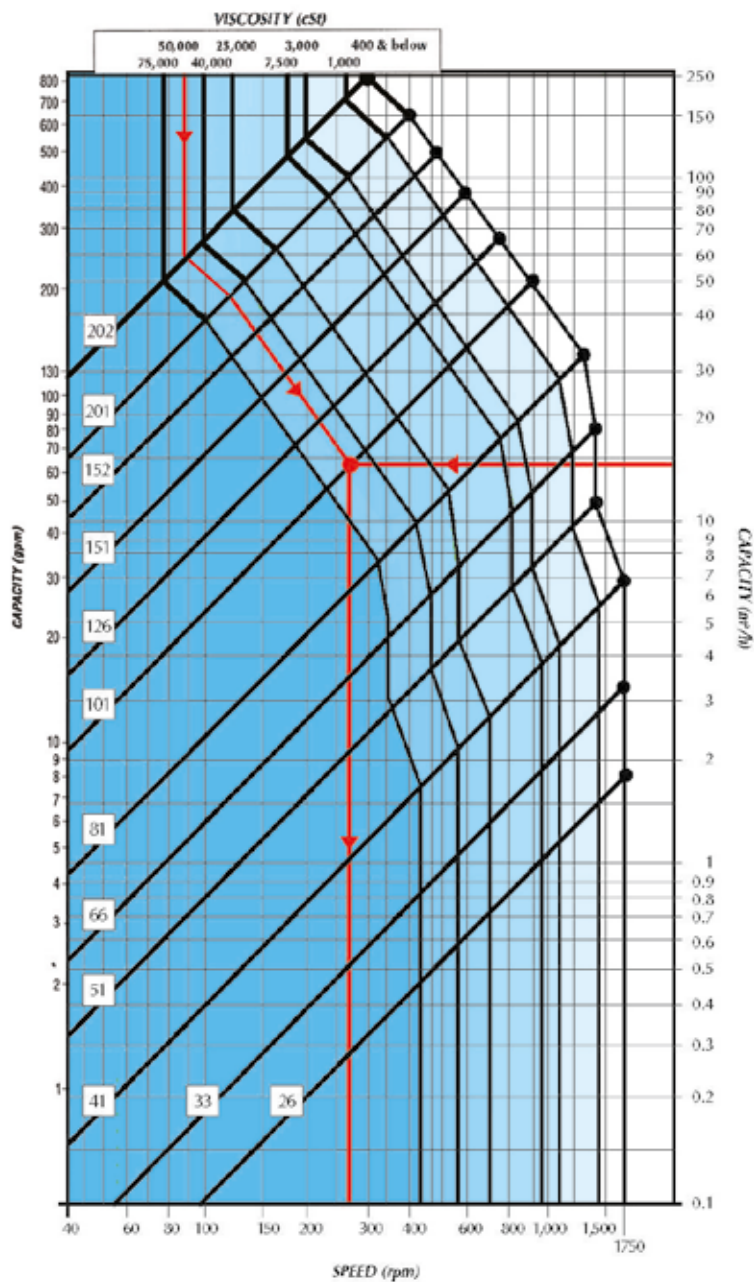

PLEASE NOTE!

ED: Capacity curve up to 151

GP: Capacity curve up to 101

To select the pump size with this table, you should only know:

- The capacity
- The viscosity

We start at the top of the table with the viscosity, and draw a line down, staying within the colour of the selected viscosity range (see example).

Then we start at the right of the table, drawing a horizontal line starting with the required capacity (see example).

The point where these two lines meet determines the pump size, defined by the diagonal lines in the table. If you do not hit one of these pump lines exactly, increase the capacity a bit. The speed is found vertically below the point of intersection (see example).

The maximum speed of each pump is found vertically below the end of each pump line (indicated with the small black dot). This maximum speed must be reduced to max. 50% when pumping strongly abrasive liquids or emulsions.

When the differential pressure is known, the shaft power is calculated by:

$$E(KW) = 0,07 \times \text{flow (m}^3/\text{h)} \times \text{differential pressure (bar)}$$

The requested shaft power has to be increased by up to 35% when using a small ROTAN® pump in combination with high viscosity (Over 10,000 cSt).

The requested shaft power has to be decreased by up to 35% when using a big ROTAN® pump in combination with low viscosity (Under 500 cSt).

www.desmi.com

DESMI

Authorized Distributor:

www.trimcorph.com

TRIMCOR TRIUMPH MACHINERY CORPORATION
THE PUMP, MOTOR & DRIVES SPECIALIST